

REV	DATE	CHANGE DESCRIPTION	MOD. BY	CK1	CK2
B1	01/07/2013	REMOVED ETCHING INFORMATION	ZS		

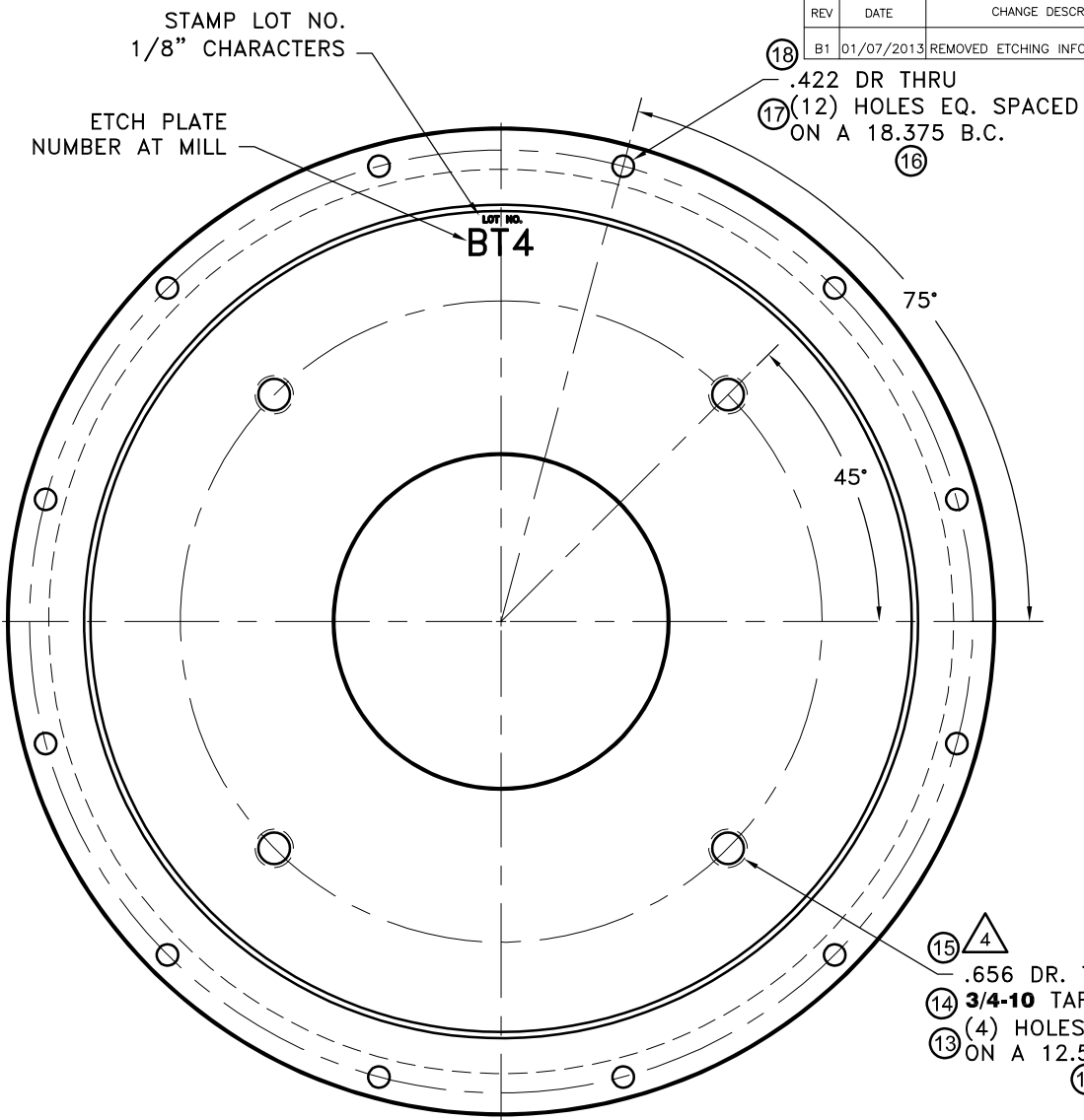
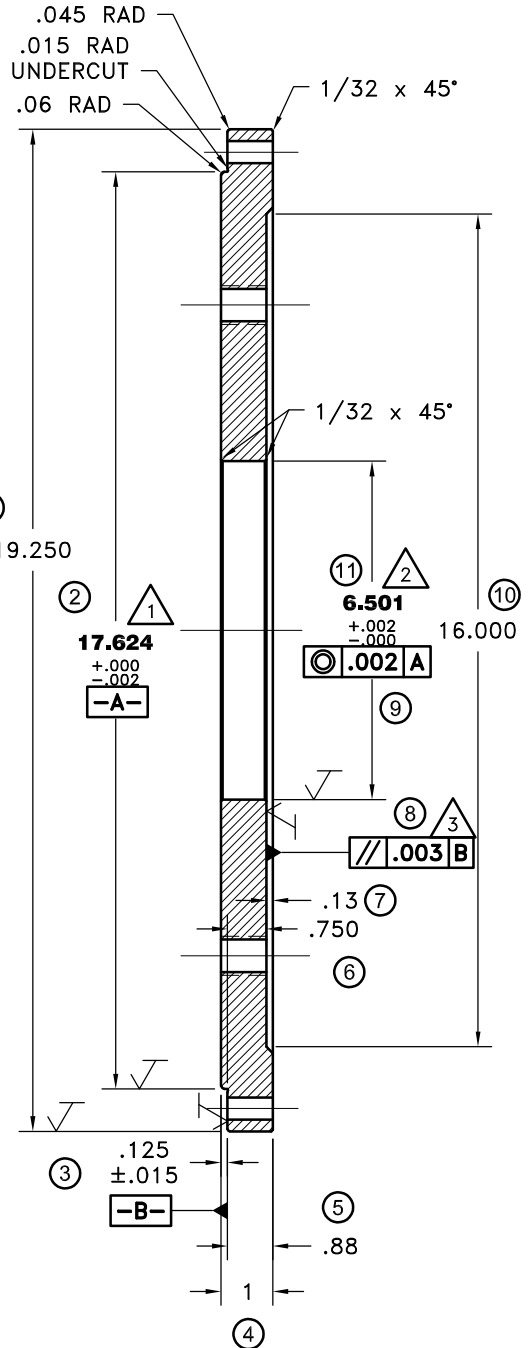

- ① 19.250
- ② 17.624 +.000 -0.002 -A-
- ③ .125 ±.015 -B-
- ④ 1
- ⑤ .88
- ⑥ .750
- ⑦ .13
- ⑧ .003 B
- ⑨ .002 A
- ⑩ 16.000
- ⑪ 6.501 +.002 -0.000
- ⑫ 12.500
- ⑬ 12.500
- ⑭ 3/4-10 TAP THRU
- ⑮ .656 DR. THRU
- ⑯ 18.375
- ⑰ 18.375
- ⑱ .422 DR THRU

THIS DRAWING IS THE PROPERTY OF HAYES MFG. INC. AND IS LOANED SUBJECT TO THE CONDITION THAT IT SHALL NOT BE REPRODUCED, COPIED, LOANED OR OTHERWISE DISPOSED OF, DIRECTLY OR INDIRECTLY. IT SHALL BE USED AS A MEANS OF REFERENCE TO WORK FURNISHED BY THIS COMPANY ONLY AND IS NOT TO BE SUBMITTED TO OUTSIDE PARTIES FOR EXAMINATION WITHOUT OUR CONSENT.

# = CRITICAL FEATURE

SYMBOLS	DET.	PART NUMBER	DESCRIPTION	QTY.
<ul style="list-style-type: none"> <li>FLATNESS</li> <li>STRAIGHTNESS</li> <li>ANGULARITY</li> <li>PERPENDICULARITY</li> <li>PARALLELISM</li> <li>CONCENTRICITY</li> <li>TRUE POSITION</li> <li>ROUNDNESS</li> <li>CIRCULAR RUN OUT</li> <li>TOTAL RUN OUT</li> <li>CYLINDRICITY</li> <li>FINISH</li> </ul>	DO NOT SCALE DRAWING TOLERANCES UNLESS OTHERWISE SPECIFIED 125 MAXIMUM ANGLE ±1/2° FRACTION ±1/32 DECIMAL .00 ±.01 .000 ±.005 .0000 ±.0005	MAKE: <input checked="" type="checkbox"/> BUY: <input type="checkbox"/>	<b>HAYES</b> MANUFACTURING INC. ® <b>PUMP MOUNT PLATE</b> MATERIAL: 123008-BTR	
CLASS: PMP2 DESCRIPTION: SAE2,E4,1,PMP	DRAWN BY: SIETING CHECKED BY: RJH	DATE: 06-01-2010 SCALE:	DRAWING NO.: 123008-BT4 SHEET OF REV.	