

REV	DATE	CHANGE DESCRIPTION	MOD. BY	CK1	CK2
B	07/07/2010	CHANGED 17.625 DIM TO 17.624	PB	RJH	JM

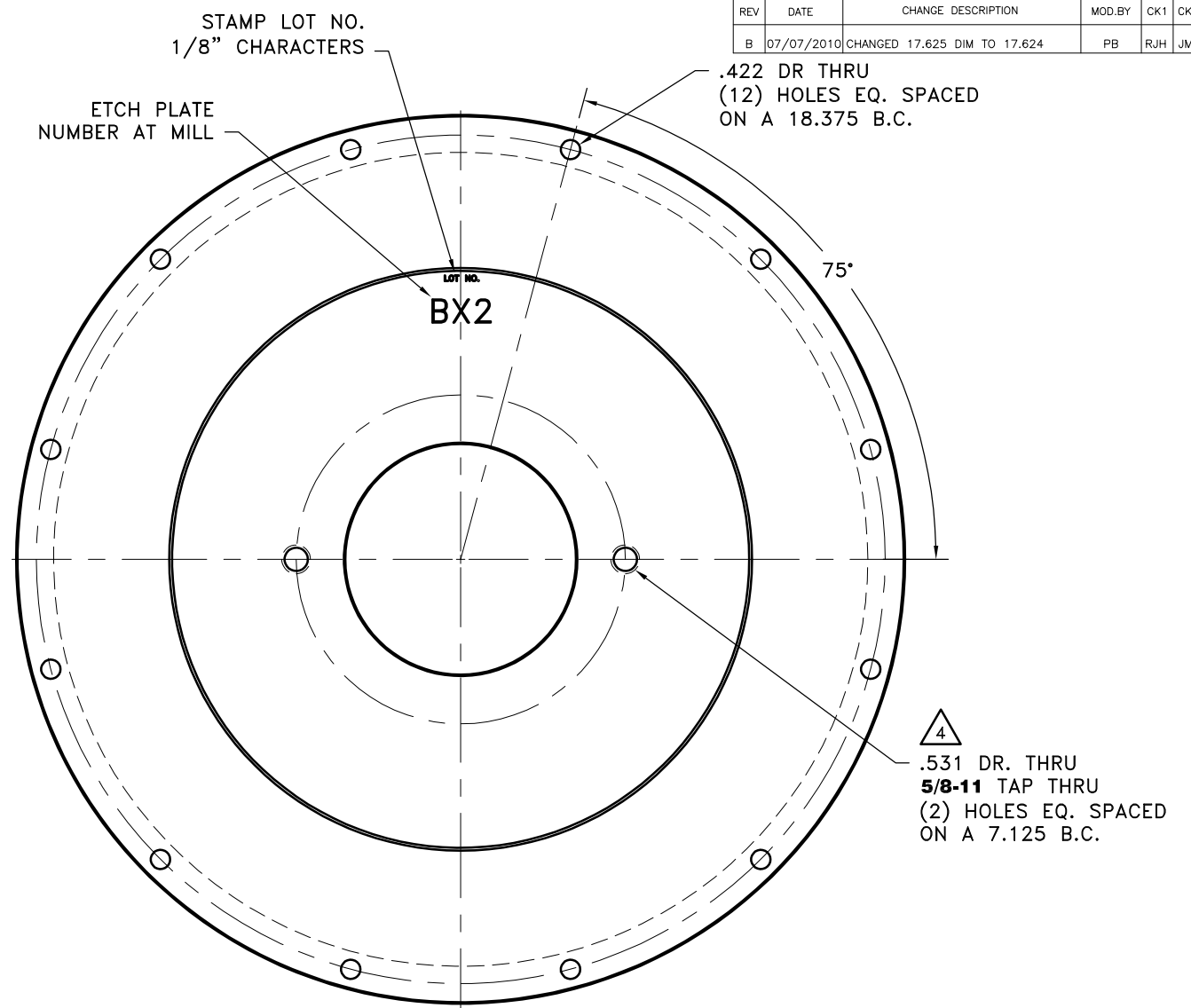
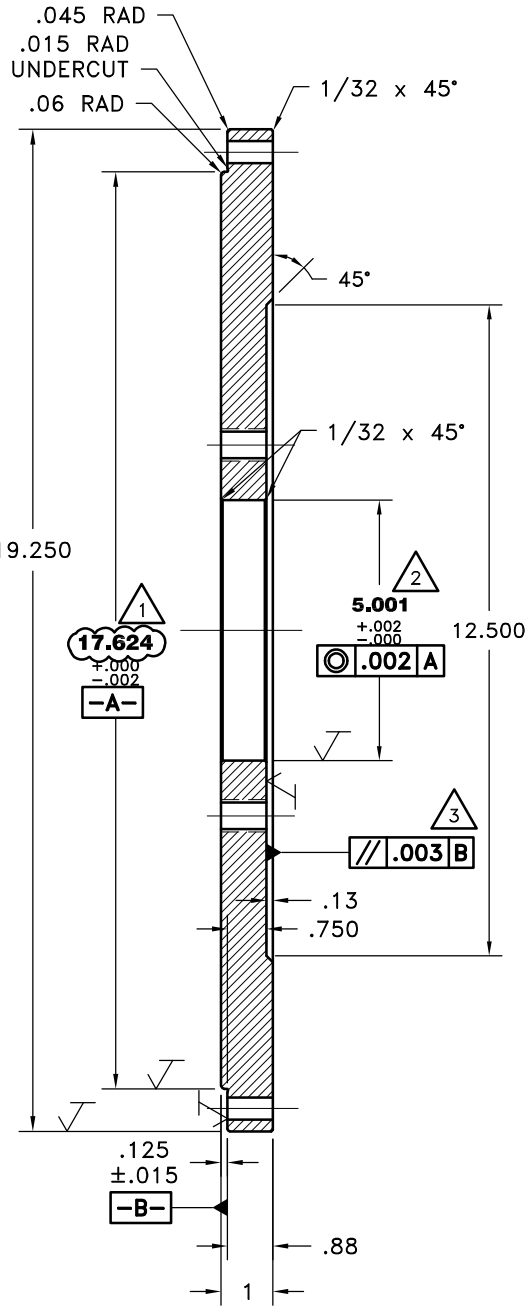

THIS DRAWING IS THE PROPERTY OF HAYES MFG. INC. AND IS LOANED SUBJECT TO THE CONDITION THAT IT SHALL NOT BE REPRODUCED, COPIED, LOANED OR OTHERWISE DISPOSED OF, DIRECTLY OR INDIRECTLY. IT SHALL BE USED AS A MEANS OF REFERENCE TO WORK FURNISHED BY THIS COMPANY ONLY AND IS NOT TO BE SUBMITTED TO OUTSIDE PARTIES FOR EXAMINATION WITHOUT OUR CONSENT.

= CRITICAL FEATURE

SYMBOLS		DET.	PART NUMBER	DESCRIPTION	QTY.
	FLATNESS	DO NOT SCALE		<b>HAYES</b> MANUFACTURING INC. ®	
	STRAIGHTNESS	DRAWING			TITLE
	ANGULARITY	TOLERANCES UNLESS OTHERWISE SPECIFIED		MATERIAL	123008-BXR
	PERPENDICULARITY	125 MAXIMUM		CLASS	PMP2
	PARALLELISM	ANGLE ±1/2°	MAKE: <input checked="" type="checkbox"/> BUY: <input type="checkbox"/>	DESCRIPTION	SAE2,C2,1,PMP
	CONCENTRICITY	FRACTION ±1/32	DRAWN BY	DATE	03-01-2010
	TRUE POSITION	DECIMAL	SIETING	CHECKED BY	RJH
	CIRCULAR RUN OUT	.00 ±.01	SCALE	DRAWING NO.	123008-BX2
	TOTAL RUN OUT	.000 ±.005		SHEET	OF
	CYLINDRICITY	.0000 ±.0005		REV.	
	FINISH				