

REV	DATE	CHANGE DESCRIPTION	MOD. BY	CK1	CK2

(12) 27/64 HOLES
EQ. SPACED
ON A 18 3/8 B.C.

(4) 1/2-13 TAPPED
HOLES EQ. SPACED
ON A 6 3/8 B.C.

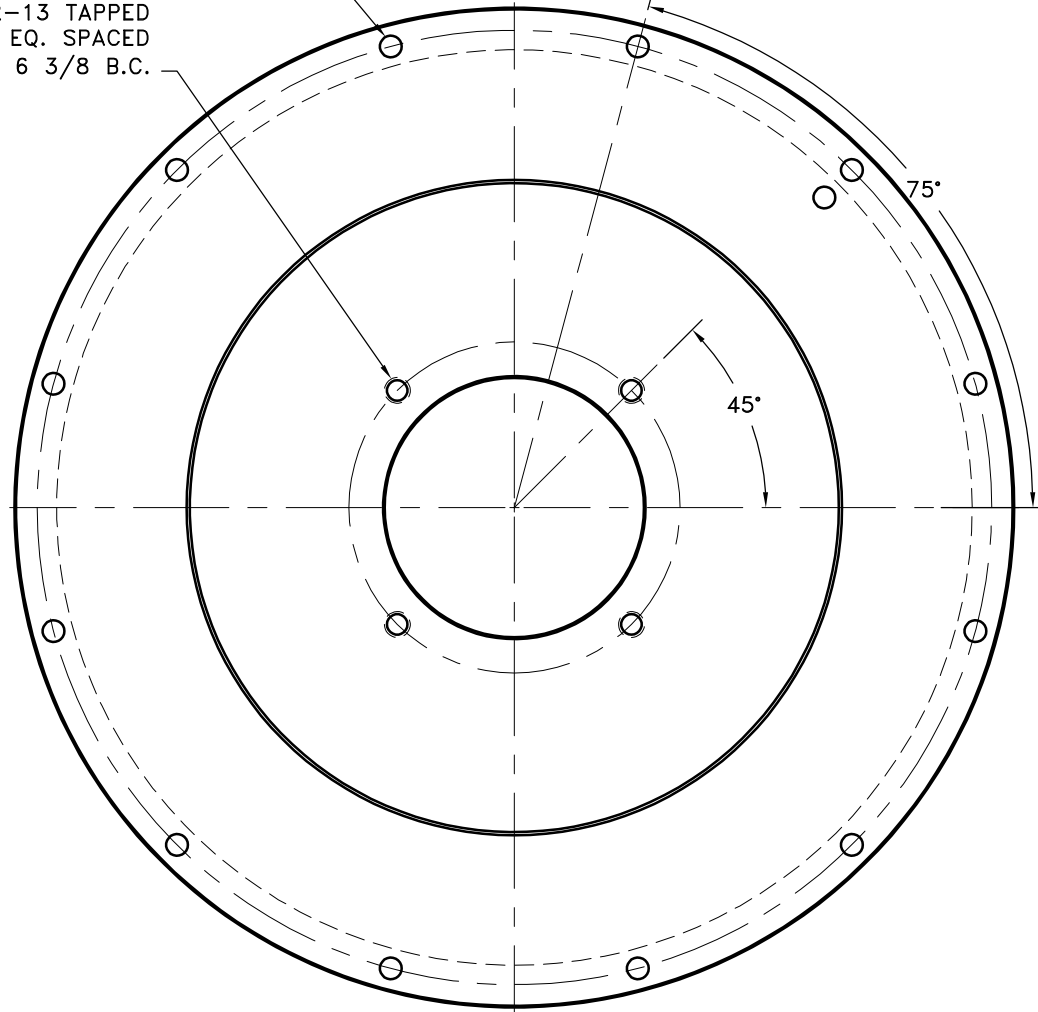
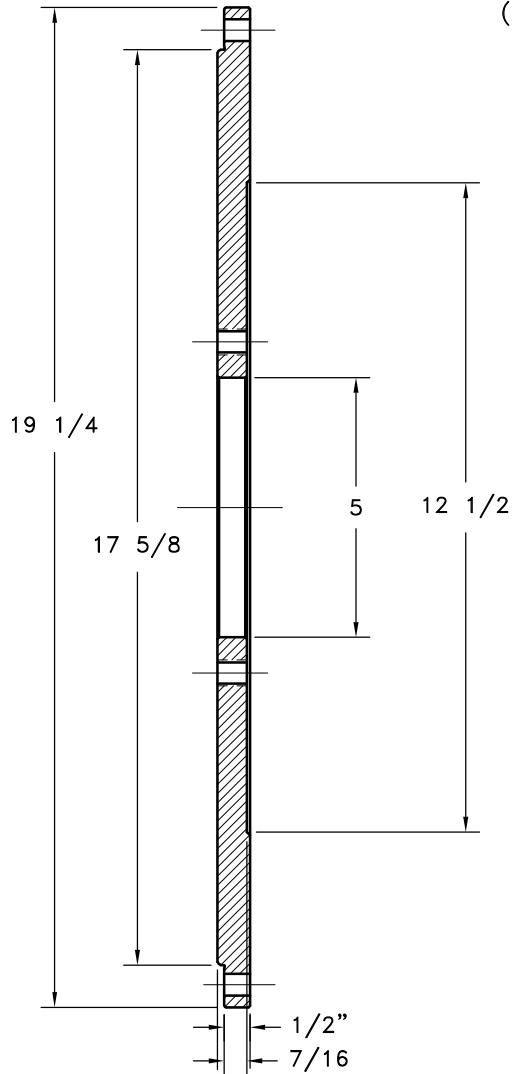

THIS DRAWING IS THE PROPERTY OF HAYES MFG. INC. AND IS LOANED SUBJECT TO THE CONDITION THAT IT SHALL NOT BE REPRODUCED, COPIED, LOANED OR OTHERWISE DISPOSED OF, DIRECTLY OR INDIRECTLY. IT SHALL BE USED AS A MEANS OF REFERENCE TO WORK FURNISHED BY THIS COMPANY ONLY AND IS NOT TO BE SUBMITTED TO OUTSIDE PARTIES FOR EXAMINATION WITHOUT OUR CONSENT.

SYMBOLS		DET.	PART NUMBER	DESCRIPTION	QTY.
	FLATNESS	DO NOT SCALE		HAYES MANUFACTURING INC. ®	
	STRAIGHTNESS	DRAWING			TITLE
	ANGULARITY	TOLERANCES UNLESS OTHERWISE SPECIFIED		SAE 2, C 4 BOLT P.M.P.	
	PERPENDICULARITY	125 MAXIMUM		MATERIAL	
	PARALLELISM	ANGLE ±1/2°			
	CONCENTRICITY	FRACTION ±1/32			
	TRUE POSITION	DECIMAL			
	ROUNDNESS	.00 ±.01			
	CIRCULAR RUN OUT	.000 ±.005			
	TOTAL RUN OUT	.0000 ±.0005			
	CYLINDRICITY				
	FINISH				
CLASS	MAKE: <input type="checkbox"/> BUY: <input type="checkbox"/>	DRAWN BY	DATE	DRAWING NO.	
DESCRIPTION		SIETING	09-10-08	123008-CX4	
		CHECKED BY	SCALE	SHEET OF	REV.
		RJH			