

REV	DATE	CHANGE DESCRIPTION	MOD.BY	CK1	CK2

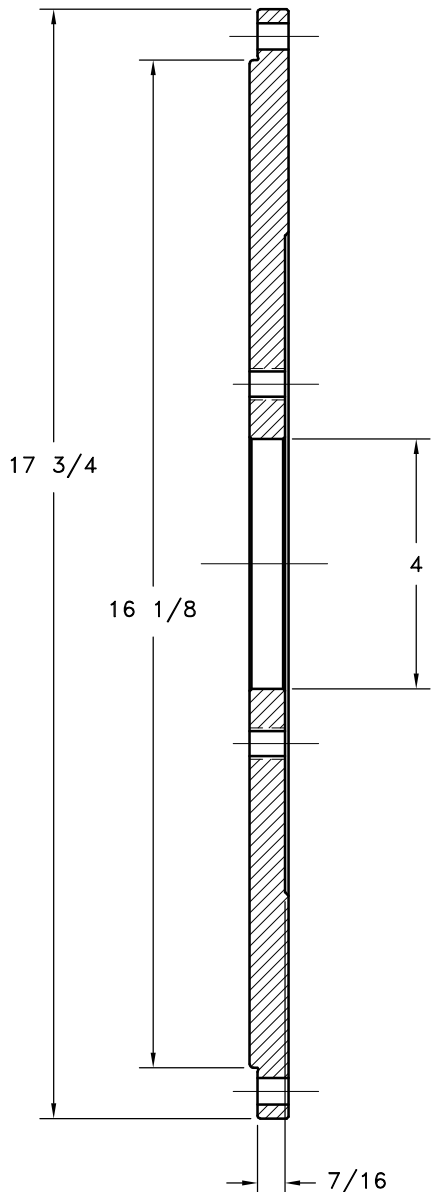

(12) 27/64 HOLES
 (2) 1/2-13 TAPPED

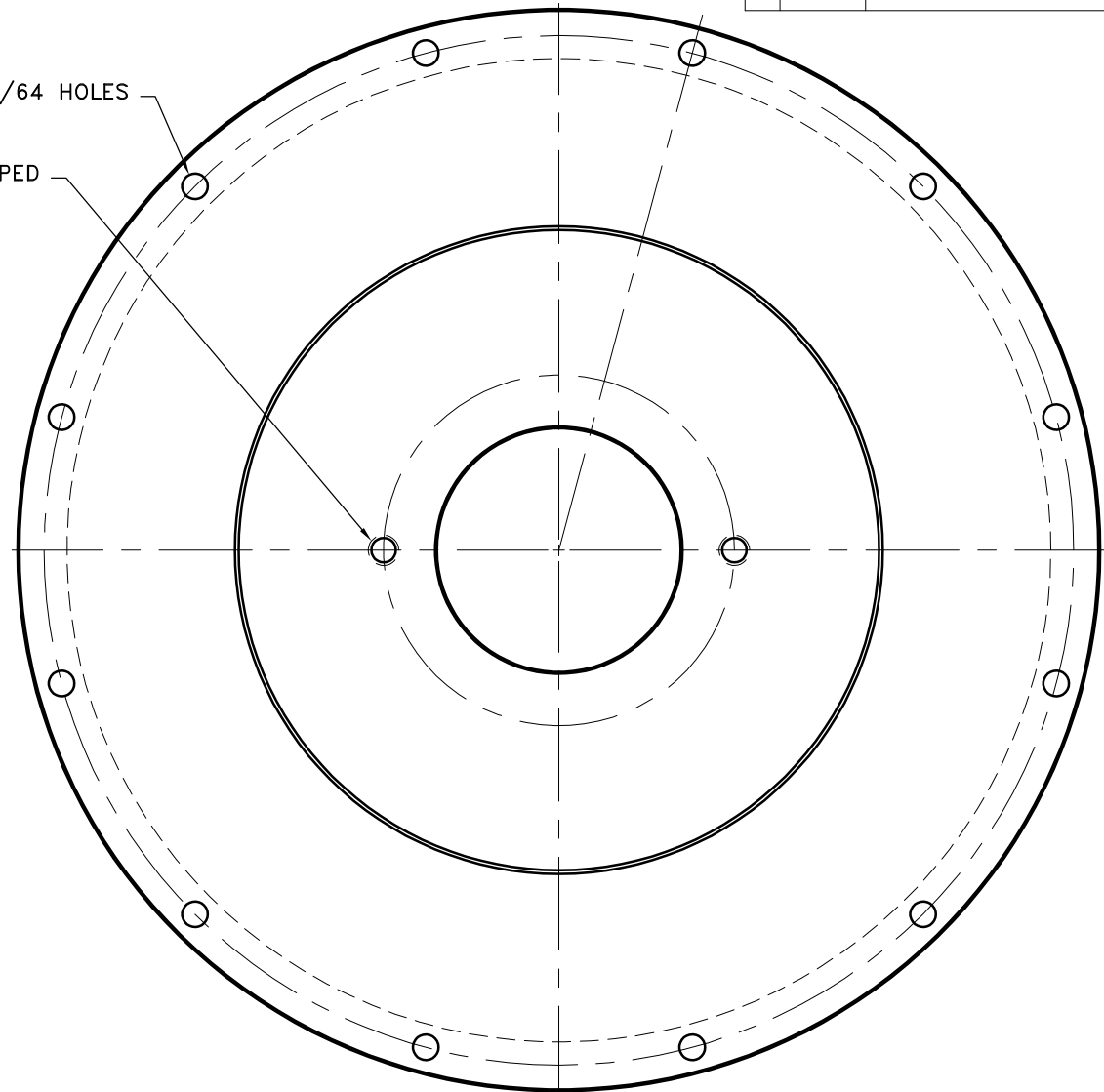

THIS DRAWING IS THE PROPERTY OF HAYES MFG. INC. AND IS LOANED SUBJECT TO THE CONDITION THAT IT SHALL NOT BE REPRODUCED, COPIED, LOANED OR OTHERWISE DISPOSED OF, DIRECTLY OR INDIRECTLY. IT SHALL BE USED AS A MEANS OF REFERENCE TO WORK FURNISHED BY THIS COMPANY ONLY AND IS NOT TO BE SUBMITTED TO OUTSIDE PARTIES FOR EXAMINATION WITHOUT OUR CONSENT.

SYMBOLS	DET.	PART NUMBER	DESCRIPTION	QTY.
▨ FLATNESS — STRAIGHTNESS ∠ ANGULARITY ⊥ PERPENDICULARITY ∥ PARALLELISM ⊙ CONCENTRICITY ⊕ TRUE POSITION ○ ROUNDNESS ⌀ CIRCULAR RUN OUT ⌀ TOTAL RUN OUT ⌀ CYLINDRICITY ✓ FINISH	DO NOT SCALE DRAWING TOLERANCES UNLESS OTHERWISE SPECIFIED 125° MAXIMUM ANGLE ±1/2° FRACTION ±1/32 DECIMAL .00 ±.01 .000 ±.005 .0000 ±.0005	MAKE: <input type="checkbox"/> BUY: <input type="checkbox"/>	HAYES MANUFACTURING INC. ® TITLE SAE 3, B 2 BOLT P.M.P. MATERIAL 5/8" PLATE	DRAWN BY SIETING CHECKED BY RJH DATE 09-13-05 SCALE DRAWING NO. 123008-DO2 SHEET OF REV.