

REV	DATE	CHANGE DESCRIPTION	MOD. BY	CK1	CK2
G	08/05/2010	CHANGED TO THREADED INSERTS	PB	RJH	JM

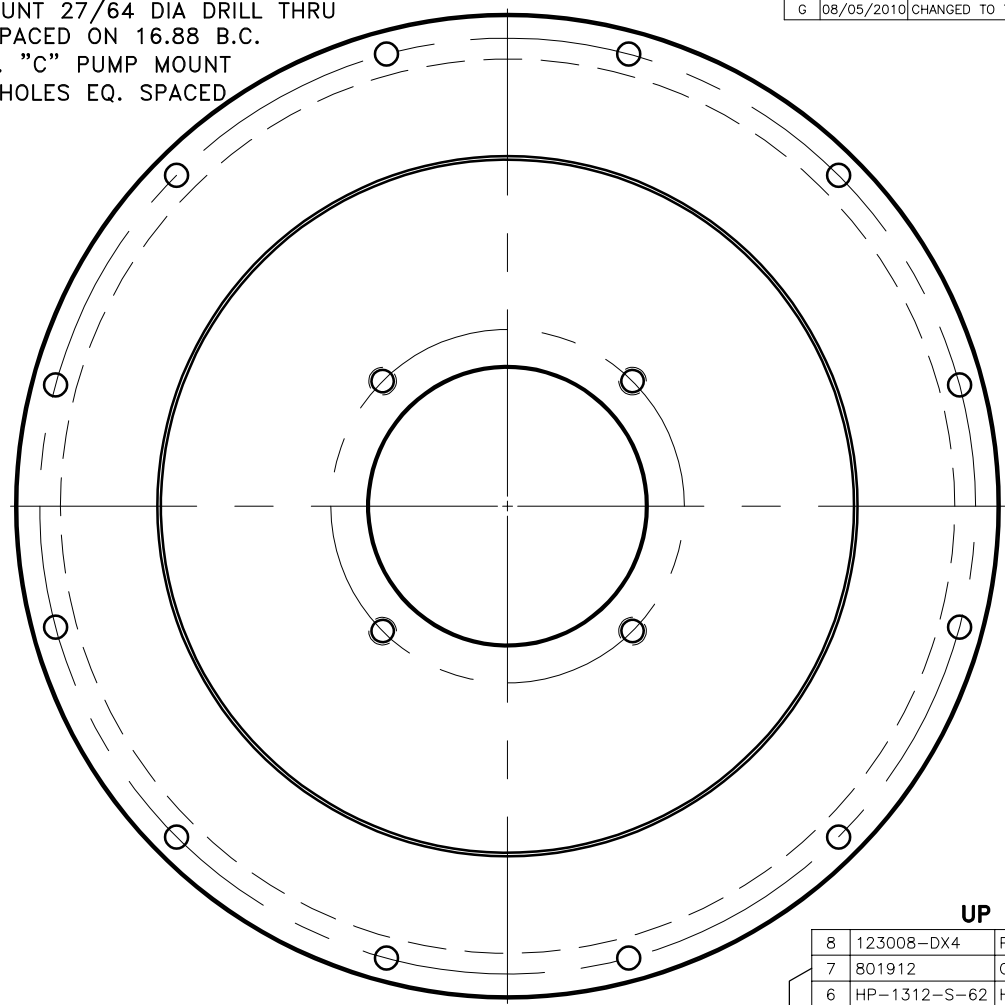
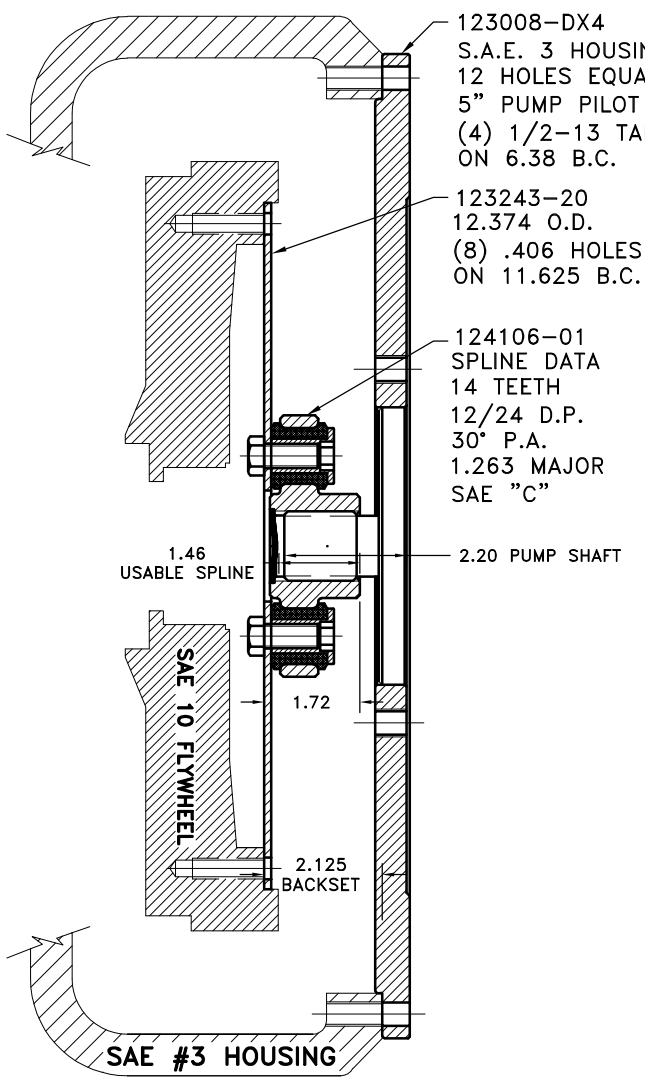

COUPLING ASS'Y #123366

UP TO 65 HP

QTY.	DESCRIPTION	PART NUMBER	DET.
1	PUMP MOUNT PLATE	123008-DX4	8
1	GREASE	801912	7
1	HUBBARD PLUG	HP-1312-S-62	6
6	THREADED BUSHING	123727	4
6	NEOPRENE INSERT	H62500	3
1	COUPLING HUB	124106-01	2
1	FLYWHEEL PLATE	123243-20	1

APPLY SUPPLIED COUPLING GREASE  
TO INTERNAL AND EXTERNAL SPLINE  
AT ASSEMBLY

THIS DRAWING IS THE PROPERTY OF HAYES MFG. INC. AND IS LOANED  
SUBJECT TO THE CONDITION THAT IT SHALL NOT BE REPRODUCED,  
COPIED, LOANED OR OTHERWISE DISPOSED OF, DIRECTLY OR INDIRECTLY.  
IT SHALL BE USED AS A MEANS OF REFERENCE TO WORK FURNISHED BY  
THIS COMPANY ONLY AND IS NOT TO BE SUBMITTED TO OUTSIDE PARTIES  
FOR EXAMINATION WITHOUT OUR CONSENT.

SYMBOLS		DET.	PART NUMBER	DESCRIPTION	QTY.
	FLATNESS	DO NOT SCALE DRAWING			
	STRAIGHTNESS	TOLERANCES UNLESS OTHERWISE SPECIFIED			
	ANGULARITY	125 MAXIMUM			
	PERPENDICULARITY	ANGLE ±1/2°			
	PARALLELISM	FRACTION ±1/32			
	CONCENTRICITY	DECIMAL			
	TRUE POSITION	.00 ±.01			
	ROUNDNESS	.000 ±.005			
	CIRCULAR RUN OUT	.0000 ±.0005			
	TOTAL RUN OUT				
	CYLINDRICITY				
	FINISH				

**HAYES**  
MANUFACTURING INC. ®

TITLE FLYWHEEL COUPLING ASS'Y WITH PUMP MOUNT PLATE		DRAWN BY BRIDSON		DATE 01-16-1990		DRAWING NO. 123029	
MATERIAL		CHECKED BY		SCALE		SHEET OF REV.	