

REV	DATE	CHANGE DESCRIPTION	MOD.BY	CK1	CK2
A1	03/01/2010	MADE NEW PRINTS	ZS	HM	RJH

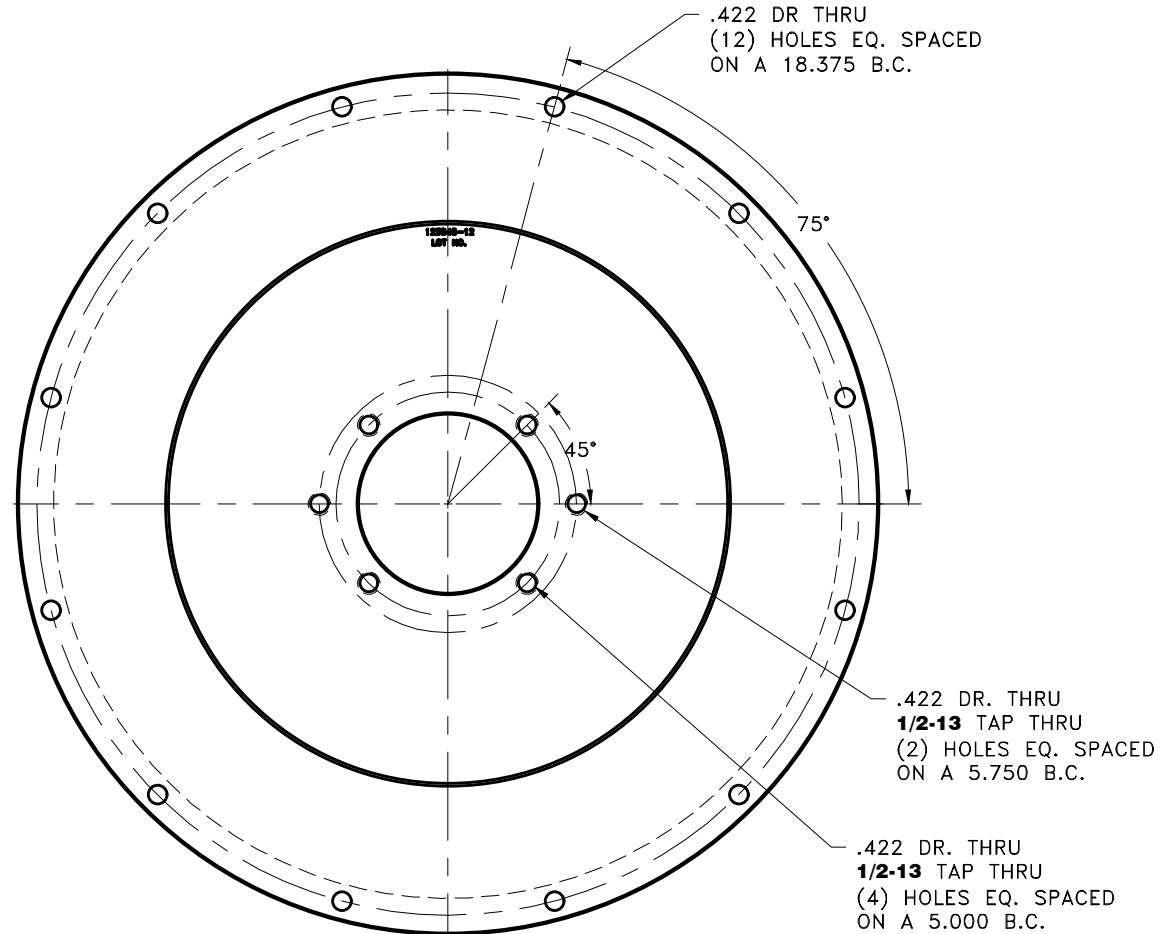
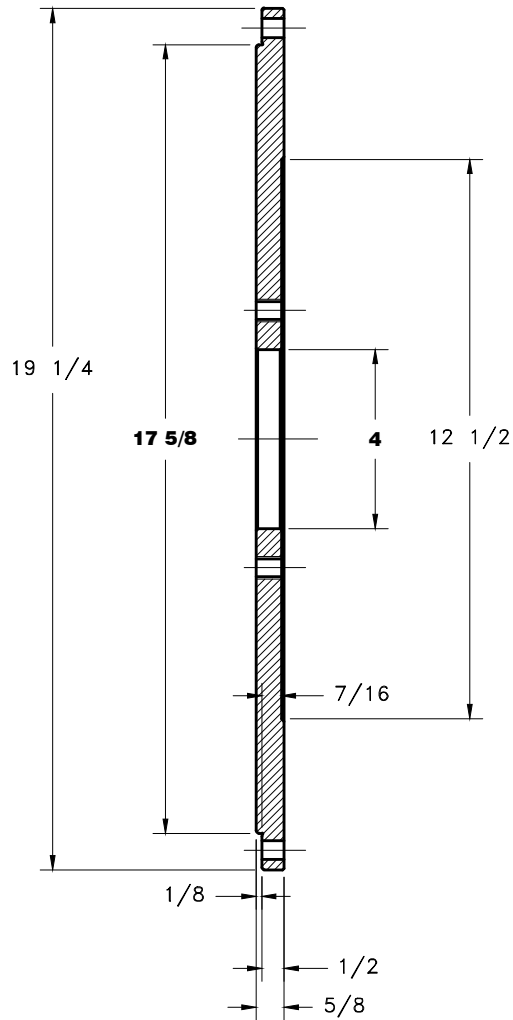

THIS DRAWING IS THE PROPERTY OF HAYES MFG. INC. AND IS LOANED SUBJECT TO THE CONDITION THAT IT SHALL NOT BE REPRODUCED, COPIED, LOANED OR OTHERWISE DISPOSED OF, DIRECTLY OR INDIRECTLY. IT SHALL BE USED AS A MEANS OF REFERENCE TO WORK FURNISHED BY THIS COMPANY ONLY AND IS NOT TO BE SUBMITTED TO OUTSIDE PARTIES FOR EXAMINATION WITHOUT OUR CONSENT.

SYMBOLS		DET.	PART NUMBER	DESCRIPTION	QTY.
	FLATNESS	DO NOT SCALE		HAYES MANUFACTURING INC. ®	
	STRAIGHTNESS	DRAWING			TITLE
	ANGULARITY	TOLERANCES UNLESS OTHERWISE SPECIFIED		PUMP MOUNT PLATE	
	PERPENDICULARITY	1/32 MAXIMUM		MATERIAL	
	PARALLELISM	ANGLE ±1/2°		123008-COR	
	TRUE POSITION	FRACTION ±1/32		DRAWN BY	DATE
	ROUNDNESS	DECIMAL		SIETING	03-01-2010
	CIRCULAR RUN OUT	.00 ±.01		CHECKED BY	SCALE
	TOTAL RUN OUT	.0000 ±.005		RJH	
	CYLINDRICITY	.0000 ±.0005			
	FINISH				
CLASS	MAKE: <input checked="" type="checkbox"/> BUY: <input type="checkbox"/>	DRAWING NO.		DRAWING NO.	
PMP2		123008-COR		123845-12	
DESCRIPTION		SAE2, B2+4, PMP		SHEET OF REV.	