

REV	DATE	CHANGE DESCRIPTION	MOD.BY	CK1	CK2

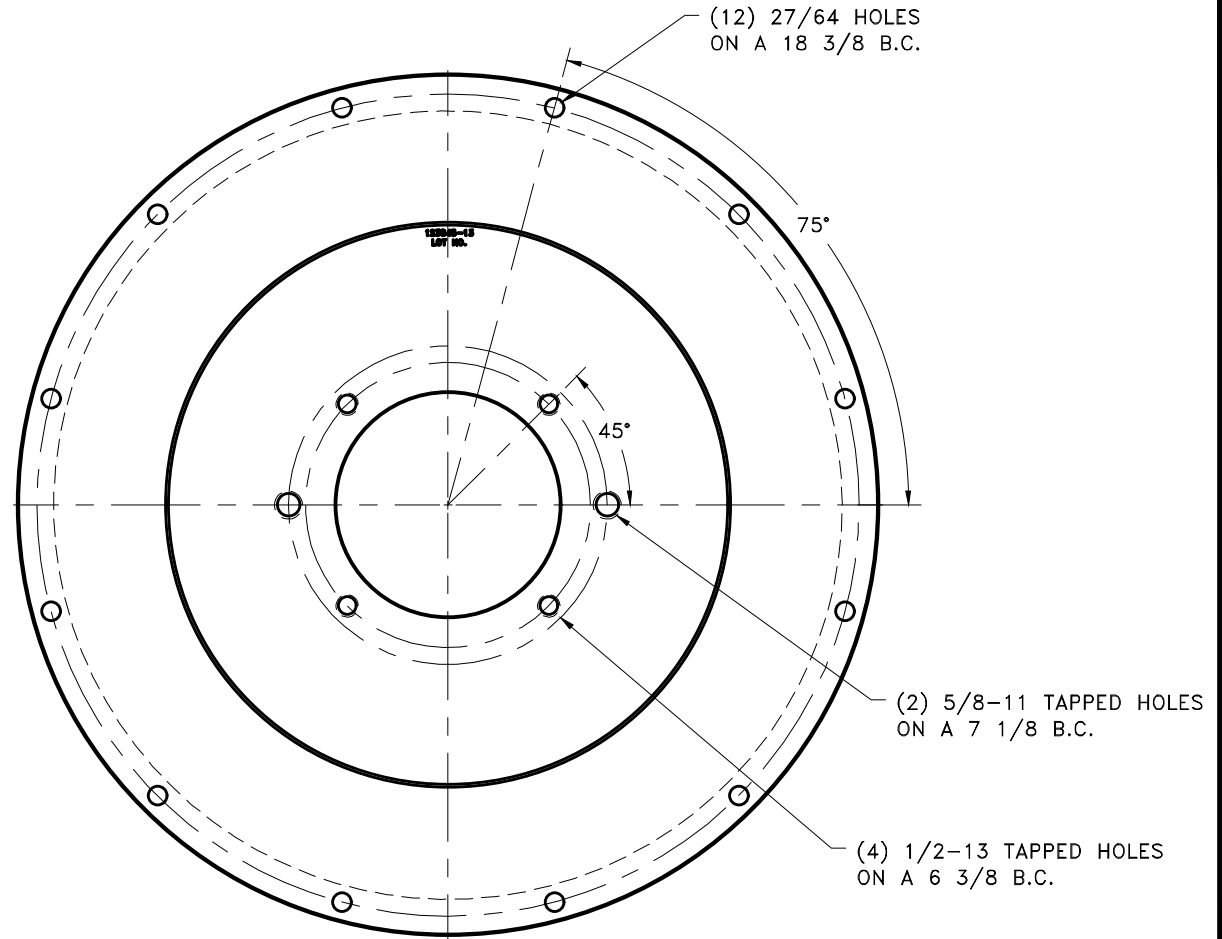
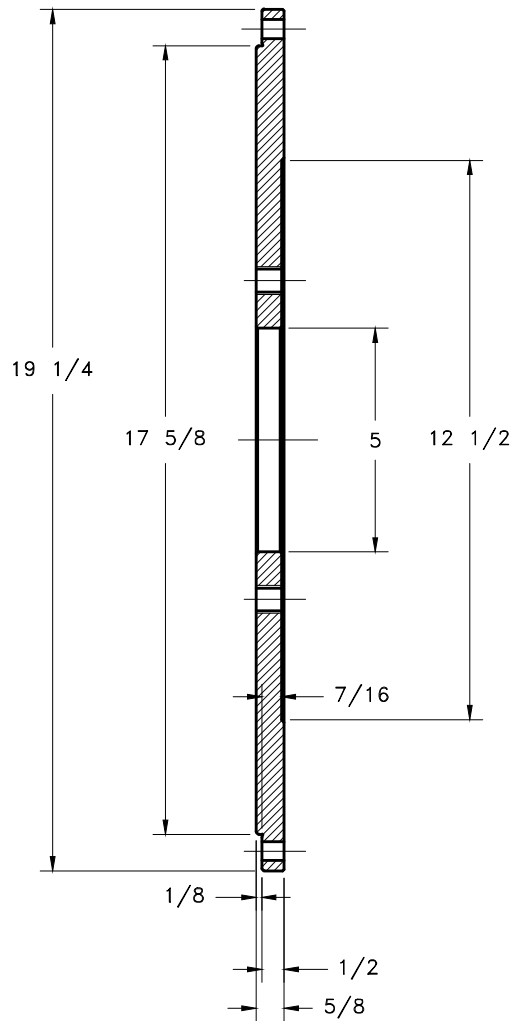

THIS DRAWING IS THE PROPERTY OF HAYES MFG. INC. AND IS LOANED SUBJECT TO THE CONDITION THAT IT SHALL NOT BE REPRODUCED, COPIED, LOANED OR OTHERWISE DISPOSED OF, DIRECTLY OR INDIRECTLY. IT SHALL BE USED AS A MEANS OF REFERENCE TO WORK FURNISHED BY THIS COMPANY ONLY AND IS NOT TO BE SUBMITTED TO OUTSIDE PARTIES FOR EXAMINATION WITHOUT OUR CONSENT.

SYMBOLS		DET.	PART NUMBER	DESCRIPTION	QTY.
	FLATNESS	DO NOT SCALE		<b>HAYES</b> MANUFACTURING INC. ®	
	STRAIGHTNESS	DRAWING			
	ANGULARITY	TOLERANCES UNLESS OTHERWISE SPECIFIED		TITLE	
	PERPENDICULARITY	1/32 MAXIMUM		PUMP MOUNT PLATE	
	PARALLELISM	ANGLE ±1/2°		MATERIAL	
	CONCENTRICITY	FRACTION ±1/32		STEEL	
	TRUE POSITION	DECIMAL		CLASS	
	ROUNDNESS	.00 ±.01		MAKE: <input type="checkbox"/> BUY: <input type="checkbox"/>	
	CIRCULAR RUN OUT	.000 ±.005		DRAWN BY	DATE
	TOTAL RUN OUT	.0000 ±.0005		SIETING	03-01-2010
	CYLINDRICITY			CHECKED BY	SCALE
	FINISH			RJH	
				DRAWING NO.	
				123845-13	
				SHEET OF REV.	