

REV	DATE	CHANGE DESCRIPTION	MOD.BY	CK1	CK2
C1	07/20/2005	UPADTED PRINT	ZS	RJH	HM

PT# 123008-DS4
 S.A.E HOUSING MOUNT 27/64 DRILL THRU
 12 HOLES EQUALLY SPACED ON 16.88 B.C.
 6" PUMP PILOT S.A.E. "D" PUMP MOUNT.
 (4) 3/4-10 TAPPED HOLES EQUALLY
 SPACED ON 9" B.C.

123243-19
 12.374 O.D.
 (8) .406 HOLES
 ON 11.625 B.C.

123214-15
 SPLINE DATA:
 21 TEETH
 W45x2x30x21x9H
 DIN 5480
 1.790 MAJOR

PUMP
 OR
 MOTOR

2.362 SHAFT LENGTH

2.125
 BACKSET

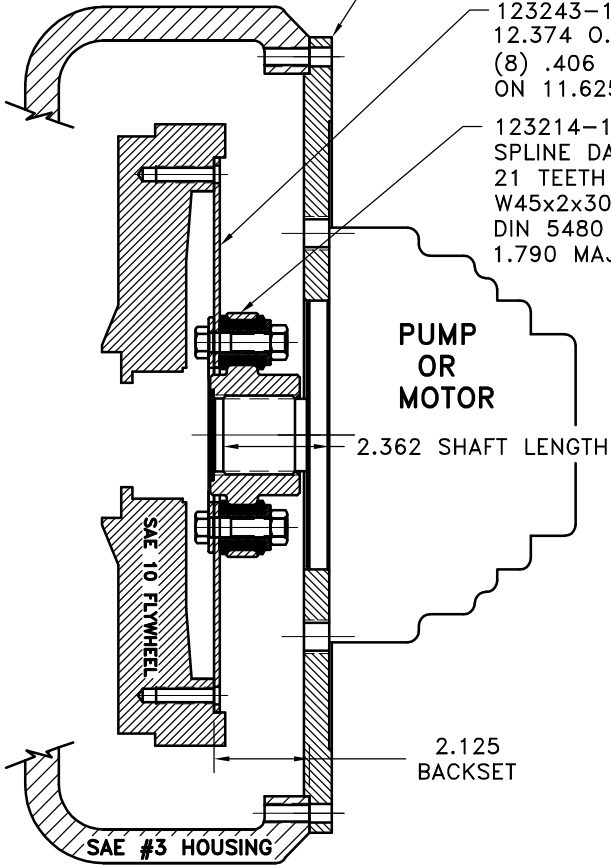
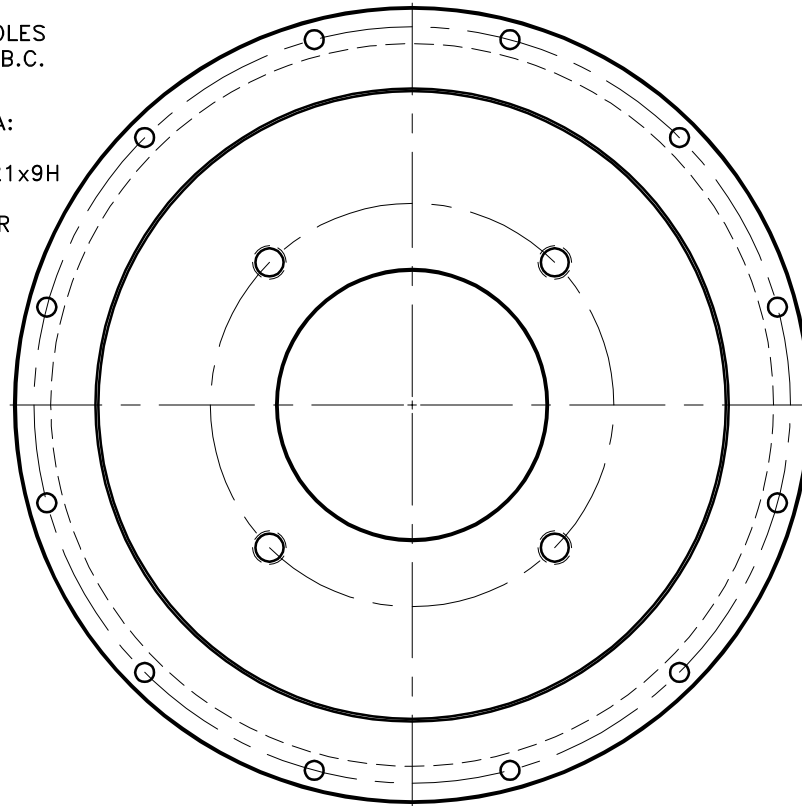

UP TO 120 HP

QTY.	PART NUMBER	DESCRIPTION
1	123008-DS4	PUMP MOUNT PLATE [3\D4BOLT]
1	801912	GREASE
1	HP-2000-S-62	HUBBARD PLUG
6	N250	7/16-20 NUT
6	HX230	7/16-20 x 1 3/4" HHB
6	123000-00	STEEL BUSHING
6	H62500	NEOPRENE INSERT
1	123214-15	COUP HUB [W45x2\4.125]
1	124623	BACKING PLATE
1	123243-19	FLYWHEEL PLATE [10\4.125]

COUPLING ASS'Y #124199

SYMBOLS		DET.	PART NUMBER	DESCRIPTION	QTY.
	FLATNESS	DO NOT SCALE			
	STRAIGHTNESS	DRAWING			
	ANGULARITY	TOLERANCES UNLESS			
	SQUARENESS	OTHERWISE SPECIFIED			
	PARALLELISM	125			
	CONCENTRICITY	MAXIMUM			
	TRUE POSITION	ANGLE ±1/2°			
	ROUNDNESS	FRACTION ±1/32			
	CIRCULAR RUN OUT	DECIMAL			
	TOTAL RUN OUT	.00 ±.01			
	CYLINDRICITY	.000 ±.005			
	FINISH	.0000 ±.0005			
- UNLESS OTHERWISE SPECIFIED - REMOVE FIRST THREAD ON ALL TAPPED HOLES		DRAWN BY		DATE	DRAWING NO.
BREAK ALL SHARP CORNERS .010 TO .020 STAMP OR MARK DRAWING NO.		SIETING		07-18-94	124198
		CHECKED BY		SCALE	SHEET OF REV.
		RJH			



TITLE
 FLYWHEEL COUPLING ASSY WITH PUMP MOUNT PLATE

MATERIAL

THIS DRAWING IS THE PROPERTY OF HAYES MFG. INC. AND IS LOANED
 SUBJECT TO THE CONDITION THAT IT SHALL NOT BE REPRODUCED,
 COPIED, LOANED OR OTHERWISE DISPOSED OF, DIRECTLY OR INDIRECTLY.
 IT SHALL BE USED AS A MEANS OF REFERENCE TO WORK FURNISHED BY
 THIS COMPANY ONLY AND IS NOT TO BE SUBMITTED TO OUTSIDE PARTIES
 FOR EXAMINATION WITHOUT OUR CONSENT.