

REV	DATE	CHANGE DESCRIPTION	MOD. BY	CK1	CK2
C1	05/03/2005	FIXED FLYWHEEL PLATE NOTE.	ZS	HM	MH

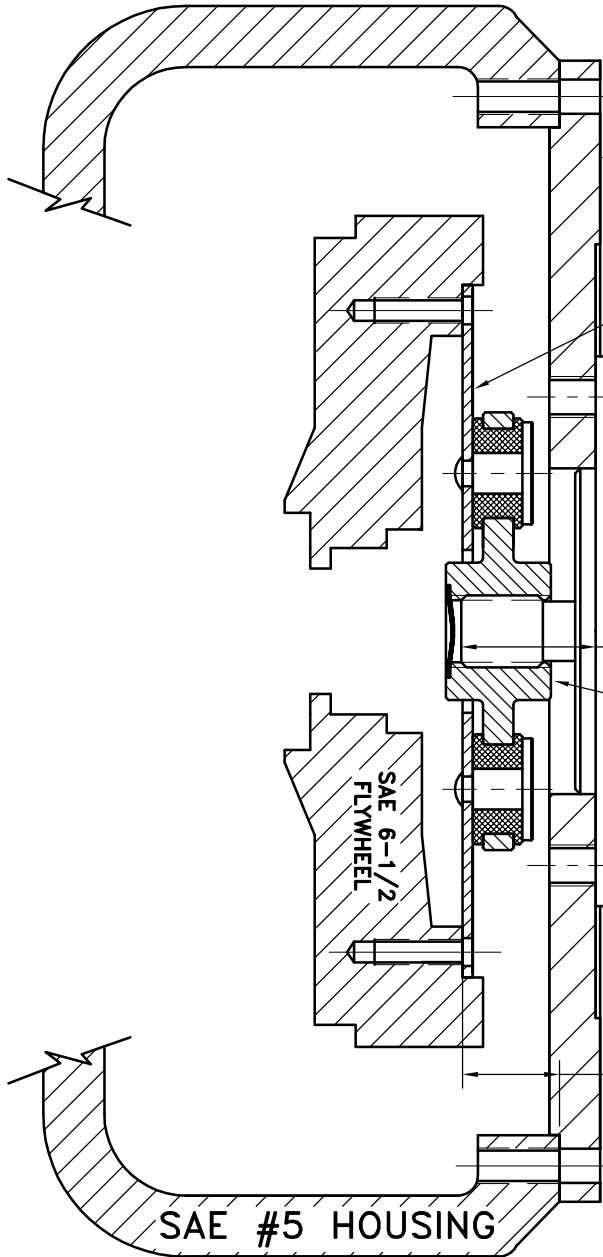

123008-G02
 S.A.E HOUSING MOUNT 27/64 DRILL
 THRU 8 HOLES EQUALLY SPACED
 ON 13.13 B.C. 4" PUMP PILOT
 S.A.E "B" PUMP MOUNT.
 (2) HOLES 1/2-13 TAPPED HOLES
 EQUALLY SPACED ON 5.75 B.C.

124243-02
 8.499 O.D.
 (6) .343 HOLES
 ON 7.875 B.C.

PUMP
 OR
 MOTOR

1.650 PUMP SHAFT

124240-10
 SPLINE DATA
 13 TEETH
 16/32 D.P.
 30° P.A.
 .885 MAJOR

1.190
 BACKSET

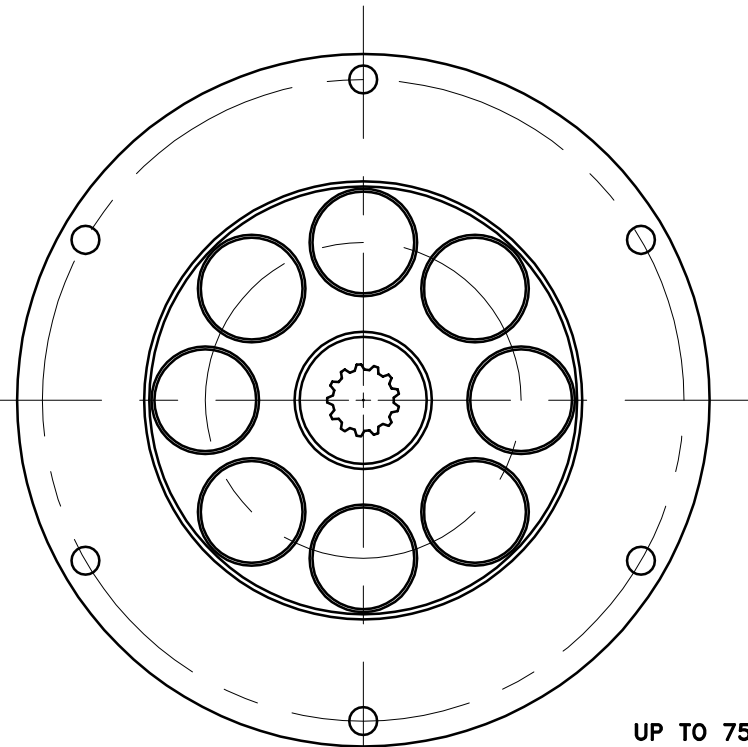

DET.	PART NUMBER	DESCRIPTION	QTY.
7	123008-G02	PUMP MOUNT PLATE	1
6	801912	GREASE	1
5	HP-1125-S-32	HUBBARD PLUG	1
4	123206-01	STEEL RIVET	8
3	H52500	NEOPRENE INSERT	8
2	124240-10	COUPLING HUB	1
1	124243-02	FLYWHEEL PLATE	1

SYMBOLS	DET.	PART NUMBER	DESCRIPTION	QTY.
▨ FLATNESS — STRAIGHTNESS ∟ ANGULARITY ⊥ SQUARENESS ∥ PARALLELISM ⊙ CONCENTRICITY ⊕ TRUE POSITION ○ ROUNDNESS ⊖ CIRCULAR RUN OUT ⊖ TOTAL RUN OUT ⊖ CYLINDRICITY ✓ FINISH	DO NOT SCALE DRAWING TOLERANCES UNLESS OTHERWISE SPECIFIED ✓ MAXIMUM ANGLE ±1/2° FRACTION ±1/32 DECIMAL .00 ±.01 .000 ±.005 .0000 ±.0005		HAYES MANUFACTURING INC. ®	
			TITLE FLYWHEEL COUPLING ASS'Y	
			MATERIAL	
			DRAWN BY HAVEMAN	DATE 3-24-97
			CHECKED BY RJH	SCALE
			DRAWING NO. 124680	SHEET OF REV.

THIS DRAWING IS THE PROPERTY OF HAYES MFG. INC. AND IS LOANED
 SUBJECT TO THE CONDITION THAT IT SHALL NOT BE REPRODUCED,
 COPIED, LOANED OR OTHERWISE DISPOSED OF, DIRECTLY OR INDIRECTLY.
 IT SHALL BE USED AS A MEANS OF REFERENCE TO WORK FURNISHED BY
 THIS COMPANY ONLY AND IS NOT TO BE SUBMITTED TO OUTSIDE PARTIES
 FOR EXAMINATION WITHOUT OUR CONSENT.