

REV. NO.	SYM.	DATE	CHANGE DESCRIPTION	DWN.
000138	A	12/00	CHANGED 123008-DQ4 TO DX4	RH

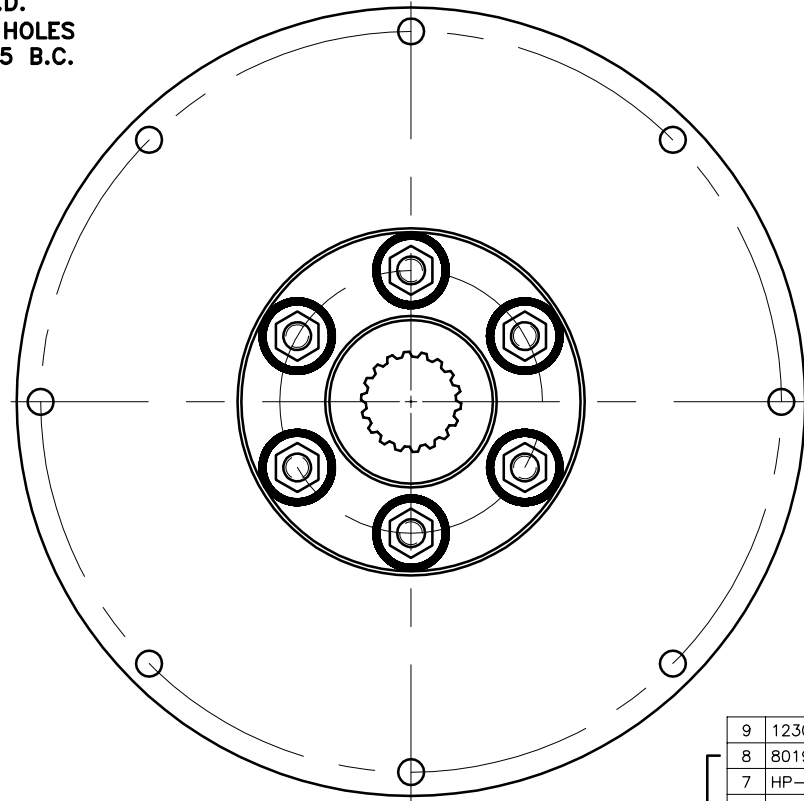
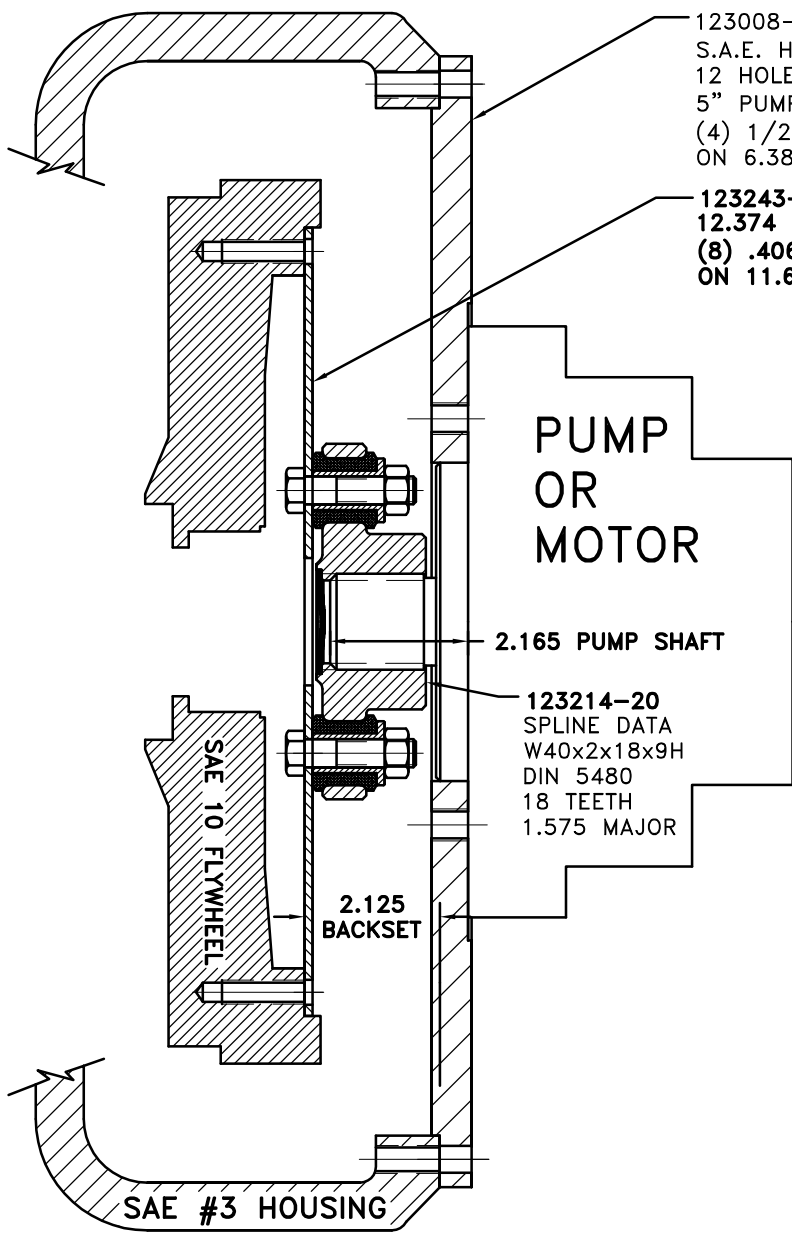

UP TO 110 HP

QTY.	PART NUMBER	DESCRIPTION
1	123008-DX4	PUMP MOUNT PLATE
1	801912	GREASE
1	HP-1312-S-62	HUBBARD PLUG
6	N250	7/16-20 NUT
6	HX230	7/16-20x1-3/4 HHB
6	123000-00	STEEL BUSHING
6	H62500	NEOPRENE INSERT
1	123214-20	COUPLING HUB
1	123243-18	FLYWHEEL PLATE

SYMBOLS	DET.	PART NUMBER	DESCRIPTION	QTY.
▭ FLATNESS — STRAIGHTNESS ∠ ANGULARITY ⊥ SQUARENESS ∥ PARALLELISM ⊕ CONCENTRICITY ⊙ TRUE POSITION ○ ROUNDNESS ⊙ CIRCULAR RUN OUT ⊙ TOTAL RUN OUT ⊙ CYLINDRICITY √ FINISH	DO NOT SCALE DRAWING TOLERANCES UNLESS OTHERWISE SPECIFIED ANGLE ±1/2° FRACTION ±1/32 DECIMAL .00 ±.01 .000 ±.005 .0000 ±.0005		HAYES TM MANUFACTURING INC.	
- UNLESS OTHERWISE SPECIFIED - REMOVE FIRST THREAD ON ALL TAPPED HOLES BREAK ALL SHARP CORNERS .010 TO .020 STAMP OR MARK DRAWING NO.			TITLE FLYWHEEL COUPLING ASS'Y WITH PUMP MOUNT PLATE MATERIAL	DRAWN BY HAVEMAN DATE 12-7-98 CHECKED BY SCALE
			DRAWING NO. 125274 SHEET OF REV.	

THIS DRAWING IS THE PROPERTY OF HAYES MFG. INC. AND IS LOANED SUBJECT TO THE CONDITION THAT IT SHALL NOT BE REPRODUCED, COPIED, LOANED OR OTHERWISE DISPOSED OF, DIRECTLY OR INDIRECTLY. IT SHALL BE USED AS A MEANS OF REFERENCE TO WORK FURNISHED BY THIS COMPANY ONLY AND IS NOT TO BE SUBMITTED TO OUTSIDE PARTIES FOR EXAMINATION WITHOUT OUR CONSENT.