

REV	DATE	CHANGE DESCRIPTION	MOD. BY	CK1	CK2
A1	08/23/2005	UPDATED PRINT	ZS	RJH	HM

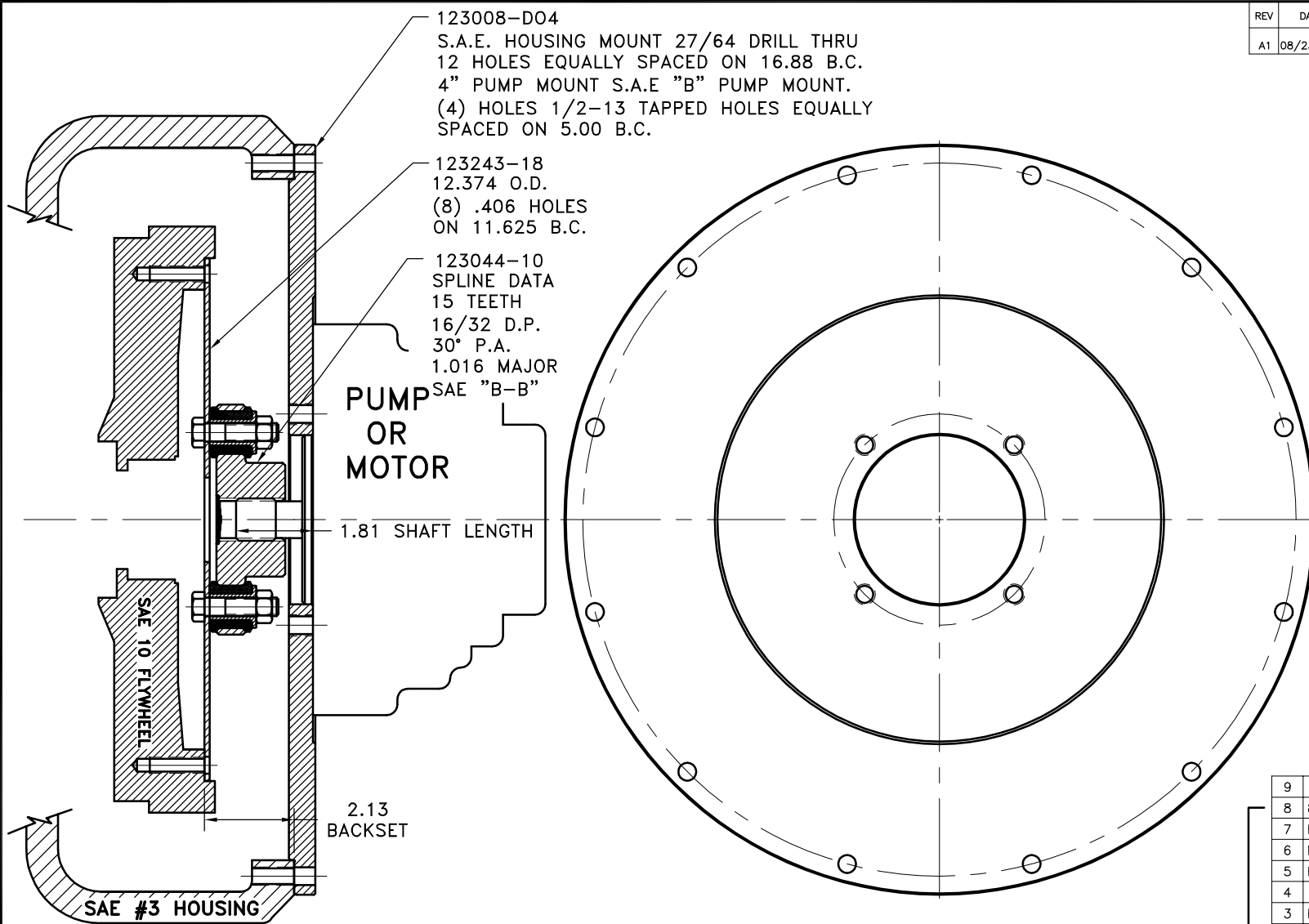

123008-DO4
S.A.E. HOUSING MOUNT 27/64 DRILL THRU
12 HOLES EQUALLY SPACED ON 16.88 B.C.
4" PUMP MOUNT S.A.E "B" PUMP MOUNT.
(4) HOLES 1/2-13 TAPPED HOLES EQUALLY
SPACED ON 5.00 B.C.

123243-18
12.374 O.D.
(8) .406 HOLES
ON 11.625 B.C.

123044-10
SPLINE DATA
15 TEETH
16/32 D.P.
30° P.A.
1.016 MAJOR
SAE "B-B"

PUMP
OR
MOTOR

1.81 SHAFT LENGTH

SAE #10 FLYWHEEL

2.13
BACKSET

SAE #3 HOUSING

COUPLING ASS'Y #124746

UP TO 110 HP

QTY.	PART NUMBER	DESCRIPTION
1	123008-DO4	PUMP MOUNT PLATE [3\B4BOLT]
1	801912	GREASE
1	HP-1125-S-32	HUBBARD PLUG
6	N250	7/16-20 NUT
6	HX230	7/16-20x1-3/4 HHB
6	123000-00	STEEL BUSHING
6	H62500	NEOPRENE INSERT
1	123044-10	COUP. HUB [15 16/32\4.125]
1	123243-18	FLYWHEEL PLATE [10\4.125]

SYMBOLS	DET.	PART NUMBER	DESCRIPTION	QTY.
FLATNESS STRAIGHTNESS ANGULARITY SQUARENESS PARALLELISM CONCENTRICITY TRUE POSITION ROUNDNESS CIRCULAR RUN OUT TOTAL RUN OUT CYLINDRICITY FINISH	DO NOT SCALE DRAWING TOLERANCES UNLESS OTHERWISE SPECIFIED MAXIMUM ANGLE ±1/2° FRACTION ±1/32 DECIMAL .00 ±.01 .000 ±.005 .0000 ±.0005			
			TITLE FLYWHEEL COUPLING ASSY WITH PUMP MOUNT PLATE MATERIAL	
			DRAWN BY SIETING	DATE 01-04-99
			CHECKED BY RJH	SCALE
			DRAWING NO. 125309	SHEET OF REV.

THIS DRAWING IS THE PROPERTY OF HAYES MFG. INC. AND IS LOANED SUBJECT TO THE CONDITION THAT IT SHALL NOT BE REPRODUCED, COPIED, LOANED OR OTHERWISE DISPOSED OF, DIRECTLY OR INDIRECTLY. IT SHALL BE USED AS A MEANS OF REFERENCE TO WORK FURNISHED BY THIS COMPANY ONLY AND IS NOT TO BE SUBMITTED TO OUTSIDE PARTIES FOR EXAMINATION WITHOUT OUR CONSENT.