

123008-DX4  
 S.A.E. 3 HOUSING MOUNT 27/64 DIA DRILL THRU  
 12 HOLES EQUALLY SPACED ON 16.88 B.C.  
 5" PUMP PILOT S.A.E. "C" PUMP MOUNT  
 (4) 1/2-13 TAPPED HOLES EQUALLY SPACED  
 ON 6.38 B.C.

123243-18  
 12.374 O.D.  
 (8) .406 HOLES  
 ON 11.625 B.C.

123214-04  
 SPLINE DATA  
 23 TEETH  
 16/32 D.P.  
 30° P.A.  
 1.525 MAJOR

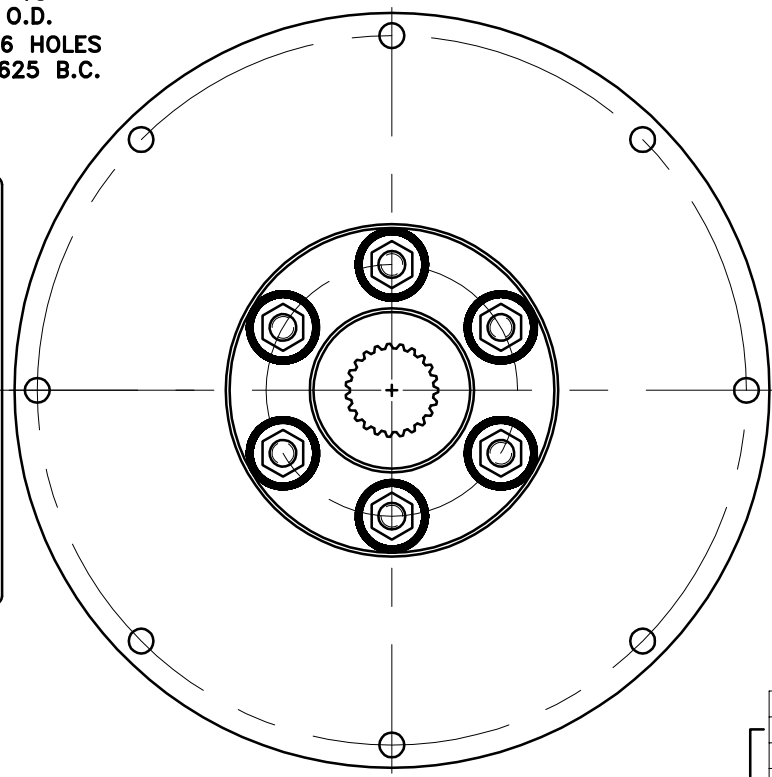

COUPLING ASS'Y  
 #125554

UP TO 110 HP

|    |              |                   |   |
|----|--------------|-------------------|---|
| 10 | 123008-DX4   | PUMP MOUNT PLATE  | 1 |
| 9  | 801912       | GREASE            | 1 |
| 8  | HP-1625-S-62 | HUBBARD PLUG      | 1 |
| 7  | N250         | 7/16-20 NUT       | 6 |
| 6  | HX230        | 7/16-20x1-3/4 HHB | 6 |
| 5  | 123000-00    | STEEL BUSHING     | 6 |
| 4  | H62500       | NEOPRENE INSERT   | 6 |
| 3  | 123214-04    | COUPLING HUB      | 1 |
| 2  | 124623       | BACKING PLATE     | 1 |
| 1  | 123243-18    | FLYWHEEL PLATE    | 1 |

| SYMBOLS   | DET.  | PART NUMBER   | DESCRIPTION     | QTY.                                   |
|---|---|---|-----------------|--|
| ▨ FLATNESS<br>— STRAIGHTNESS<br>∠ ANGULARITY<br>⊥ SQUARENESS<br>∥ PARALLELISM<br>⊙ CONCENTRICITY<br>⊕ TRUE POSITION<br>○ ROUNDNESS<br>⊘ CIRCULAR RUN OUT<br>⊘ TOTAL RUN OUT<br>⊘ CYLINDRICITY<br>√ FINISH | DO NOT SCALE DRAWING<br>TOLERANCES UNLESS OTHERWISE SPECIFIED<br>ANGLE ±1/2°<br>FRACTION ±1/32<br>DECIMAL<br>.00 ±.01<br>.000 ±.005<br>.0000 ±.0005 | <div style="text-align: center;"> <p>TM MANUFACTURING INC.</p> </div> <p>TITLE<br/>           FLYWHEEL COUPLING ASS'Y WITH PUMP MOUNT PLATE</p> <p>MATERIAL</p> |                 |  |
| - UNLESS OTHERWISE SPECIFIED -<br>REMOVE FIRST THREAD ON ALL TAPPED HOLES<br>BREAK ALL SHARP CORNERS .010 TO .020 STAMP OR MARK DRAWING NO.   |   | DRAWN BY<br>HAVEMAN   | DATE<br>2-20-01 | DRAWING NO.<br>126222<br>SHEET OF REV. |

THIS DRAWING IS THE PROPERTY OF HAYES MFG. INC. AND IS LOANED SUBJECT TO THE CONDITION THAT IT SHALL NOT BE REPRODUCED, COPIED, LOANED OR OTHERWISE DISPOSED OF, DIRECTLY OR INDIRECTLY. IT SHALL BE USED AS A MEANS OF REFERENCE TO WORK FURNISHED BY THIS COMPANY ONLY AND IS NOT TO BE SUBMITTED TO OUTSIDE PARTIES FOR EXAMINATION WITHOUT OUR CONSENT.