

REV	DATE	CHANGE DESCRIPTION	MOD.BY	CK1	CK2
A	10/03/2006	CHANGED HOUSING P/N	ZS	ML	HM

127076-28
 (6) 11/32 HOLES
 (3) 5/16 DOWEL HOLES
 EQ. SPACED ON A
 7.95 B.C.

123207-05
 SPLINE DATA
 13 TEETH
 16/32 D.P.
 30° P.A.
 .885 MAJOR
 SAE "B"

**PUMP
 OR
 MOTOR**

1.65 PUMP SHAFT

M10 x 1.5 TAPPED HOLES
 (6) HOLES AS SHOWN

3.24 FACE MNT.
 HEIGHT

1.88
 3.12
 3.74

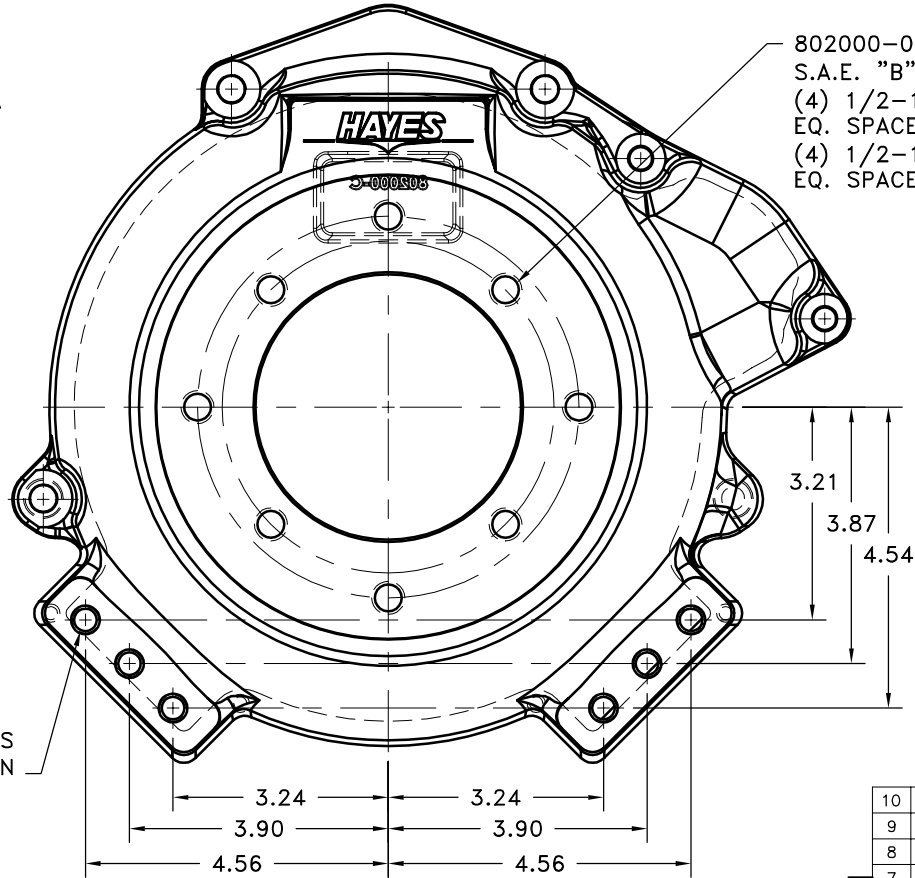

802000-07
 S.A.E. "B" PUMP MOUNT
 (4) 1/2-13 TAPPED HOLES
 EQ. SPACED ON A 5.00 B.C.
 (4) 1/2-13 TAPPED HOLES
 EQ. SPACED ON A 5.75 B.C.

UP TO 75 HP

10	802003	BOLT KIT	1
9	802002	COVER PLATE	1
8	802000-07	HOUSING	1
7	801912	GREASE	1
6	HP-1125-S-32	GREASE PLUG	1
5	HX100	5/16-24 x 5/8" HHB	6
4	H52500	NEOPRENE INSERT	6
3	123729-01	THREADED BUSHING	6
2	123207-05	COUP HUB [13T16/32\3.000]	1
1	127076-28	FLYWHEEL PLATE	1

COUPLING ASS'Y #127955

SYMBOLS	DET.	PART NUMBER	DESCRIPTION	QTY.
▱ FLATNESS — STRAIGHTNESS ∠ ANGULARITY ⊥ SQUARENESS ∥ PARALLELISM ⊙ CONCENTRICITY ⊕ TRUE POSITION ○ ROUNDNESS ⊙ CIRCULAR RUN OUT ⊖ TOTAL RUN OUT ∅ CYLINDRICITY √ FINISH	DO NOT SCALE DRAWING TOLERANCES UNLESS OTHERWISE SPECIFIED 125° MAXIMUM ANGLE ±1/2° FRACTION ±1/32 DECIMAL .00 ±.01 .000 ±.005 .0000 ±.0005			
- UNLESS OTHERWISE SPECIFIED - REMOVE FIRST THREAD ON ALL TAPPED HOLES BREAK ALL SHARP CORNERS .010 TO .020 STAMP OR MARK DRAWING NO.		DRAWN BY SIETING	DATE 08-01-05	DRAWING NO. 802004 SHEET OF REV.
		CHECKED BY RJH	SCALE	

THIS DRAWING IS THE PROPERTY OF HAYES MFG. INC. AND IS LOANED
 SUBJECT TO THE CONDITION THAT IT SHALL NOT BE REPRODUCED,
 COPIED, LOANED OR OTHERWISE DISPOSED OF, DIRECTLY OR INDIRECTLY.
 IT SHALL BE USED AS A MEANS OF REFERENCE TO WORK FURNISHED BY
 THIS COMPANY ONLY AND IS NOT TO BE SUBMITTED TO OUTSIDE PARTIES
 FOR EXAMINATION WITHOUT OUR CONSENT.