

REV	DATE	CHANGE DESCRIPTION	MOD. BY	CK1	CK2
A	01/31/2002	ADDED DUST COVER	ZS		

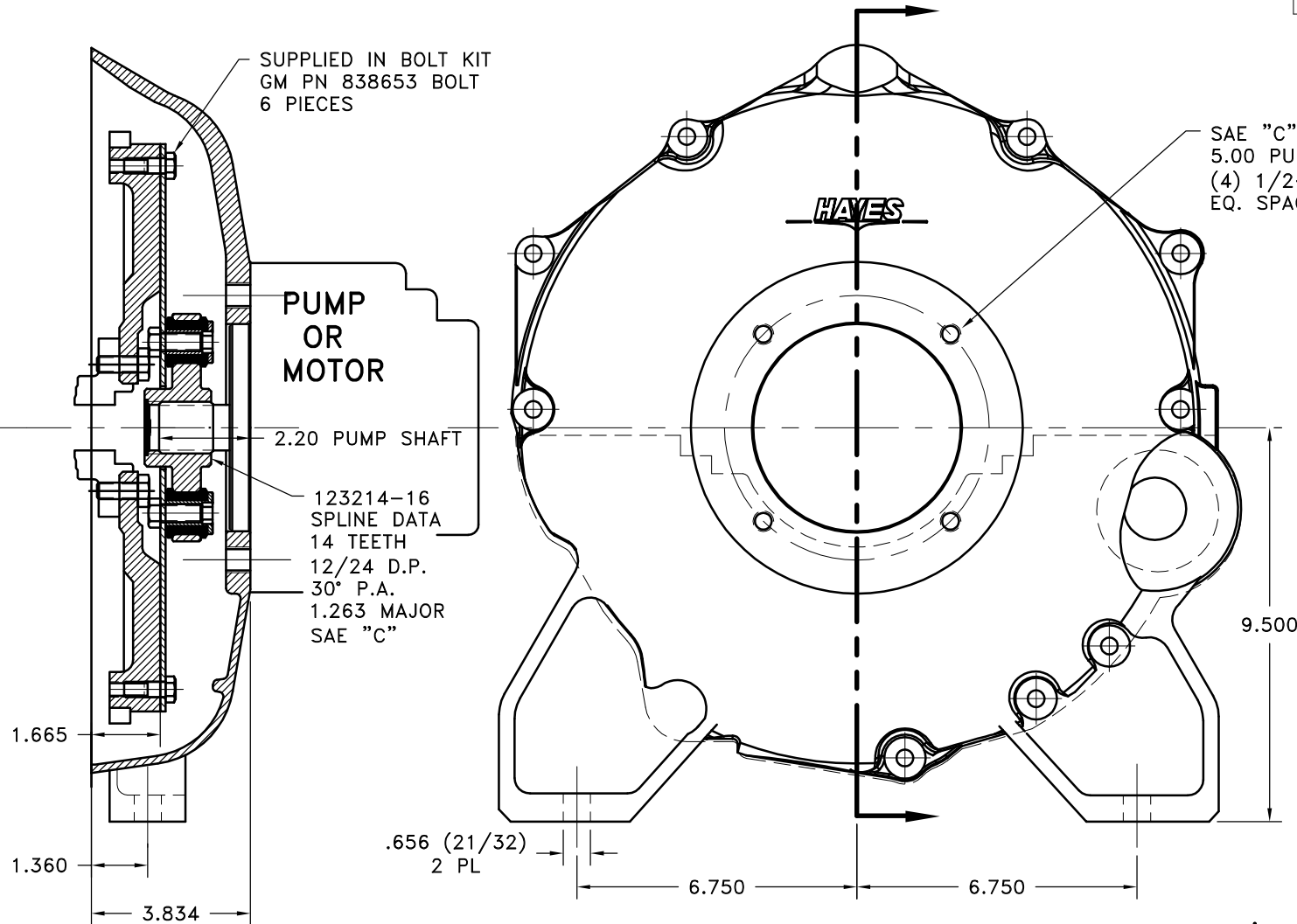

SAE "C" 4-BOLT MOUNT
5.00 PUMP PILOT
(4) 1/2-13 TAPPED HOLES
EQ. SPACED ON 6.375 B.C.

SUPPLIED IN BOLT KIT
GM PN 838653 BOLT
6 PIECES

PUMP
OR
MOTOR

2.20 PUMP SHAFT

123214-16
SPLINE DATA
14 TEETH
12/24 D.P.
30° P.A.
1.263 MAJOR
SAE "C"

1.665

1.360

3.834

.656 (21/32)
2 PL

6.750

6.750

9.500

COUPLING ASS'Y
126434

GM 3.0 LITRE

UP TO 110 HP

10	890007	3.0 LITRE DUST COVER	1
9	890002	BOLT KIT	1
8	890000-07	HOUSING	1
7	801912	GREASE	1
6	HP-1312-S-62	HUBBARD PLUG	1
5	HX200	7/16-20x1 HHB	6
4	123727	THREADED BUSHING	6
3	H62500	NEOPRENE INSERT	6
2	123214-16	COUPLING HUB	1
1	126151-02	FLYWHEEL PLATE	1

NOTE:

1. USE FURNISHED COUPLING GREASE
ON BOTH MALE & FEMALE SPLINES.

2. CAUTION: WHEN INSTALLING PUMP ON ENGINE
HOUSING BE CAREFUL BOLTS DO NOT EXTEND PAST
INSIDE FACE OF HOUSING AND RUB ON COUPLING ASS'Y.

THIS DRAWING IS THE PROPERTY OF HAYES MFG. INC. AND IS LOANED
SUBJECT TO THE CONDITION THAT IT SHALL NOT BE REPRODUCED,
COPIED, LOANED OR OTHERWISE DISPOSED OF, DIRECTLY OR INDIRECTLY.
IT SHALL BE USED AS A MEANS OF REFERENCE TO WORK FURNISHED BY
THIS COMPANY ONLY AND IS NOT TO BE SUBMITTED TO OUTSIDE PARTIES
FOR EXAMINATION WITHOUT OUR CONSENT.

SYMBOLS	DET.	PART NUMBER	DESCRIPTION	QTY.
FLATNESS STRAIGHTNESS ANGULARITY SQUARENESS PARALLELISM CONCENTRICITY TRUE POSITION ROUNDNESS CIRCULAR RUN OUT TOTAL RUN OUT CYLINDRICITY FINISH	DO NOT SCALE DRAWING TOLERANCES UNLESS OTHERWISE SPECIFIED MAXIMUM ANGLE ±1/2° FRACTION ±1/32 DECIMAL .00 ±.01 .000 ±.005 .0000 ±.0005			
			TITLE GM HOUSING & FLYWHEEL COUPLING ASS'Y	
			MATERIAL	
			DRAWN BY LAWSON	DATE 10-23-01
			CHECKED BY RJH	SCALE
			DRAWING NO. 890009	SHEET OF REV.
			- UNLESS OTHERWISE SPECIFIED - REMOVE FIRST THREAD ON ALL TAPPED HOLES BREAK ALL SHARP CORNERS .010 TO .020 STAMP OR MARK DRAWING NO.	