

REV	DATE	CHANGE DESCRIPTION	MOD. BY	CK1	CK2
A	03/17/2004	ADDED C 2-BOLT TO HOUSING	ZS	ML	HM

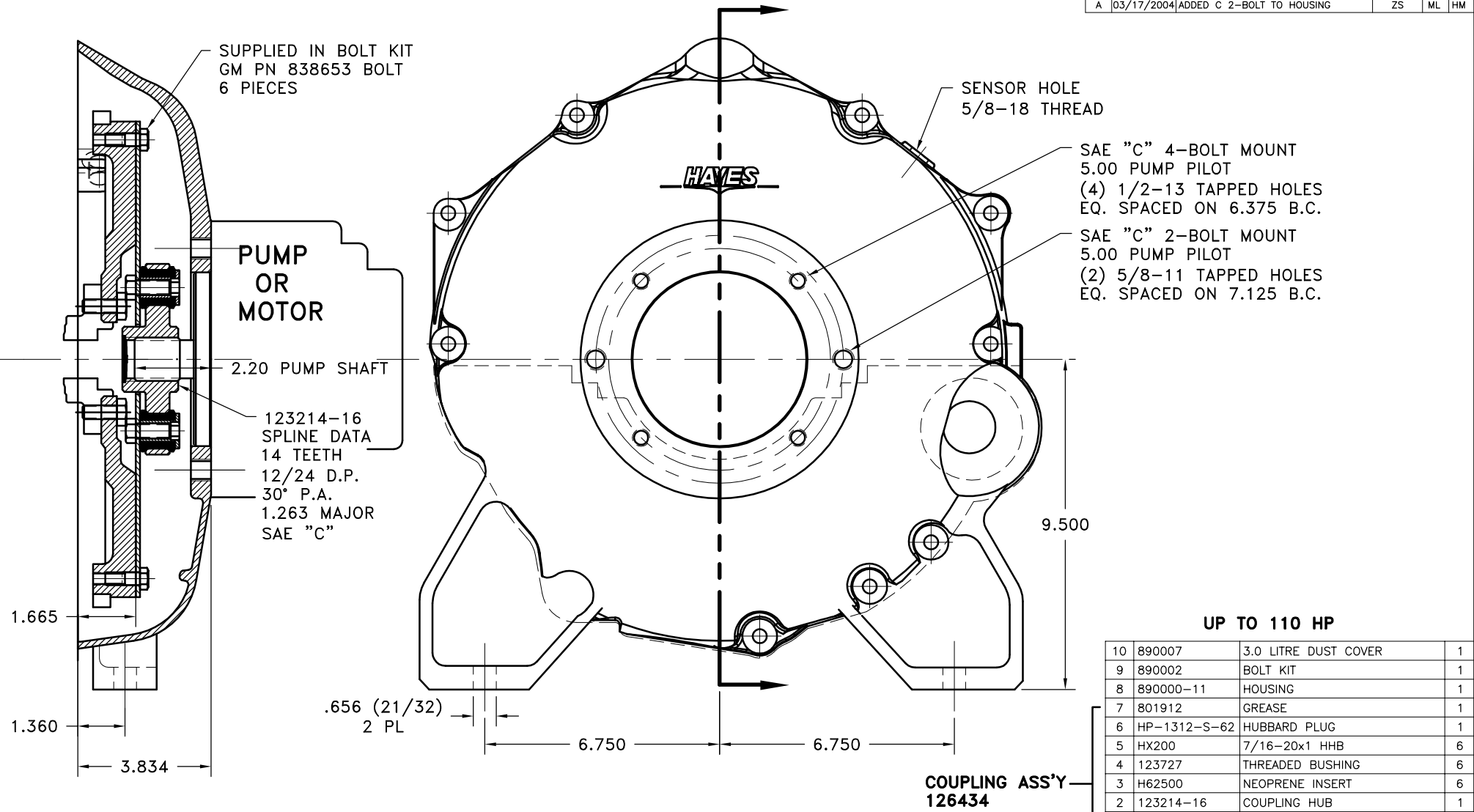

GM 3.0 LITRE

UP TO 110 HP

QTY.	PART NUMBER	DESCRIPTION
1	890007	3.0 LITRE DUST COVER
1	890002	BOLT KIT
1	890000-11	HOUSING
1	801912	GREASE
1	HP-1312-S-62	HUBBARD PLUG
6	HX200	7/16-20x1 HHB
6	123727	THREADED BUSHING
6	H62500	NEOPRENE INSERT
1	123214-16	COUPLING HUB
1	126151-02	FLYWHEEL PLATE

NOTE:

1. USE FURNISHED COUPLING GREASE ON BOTH MALE & FEMALE SPLINES.
2. CAUTION: WHEN INSTALLING PUMP ON ENGINE HOUSING BE CAREFUL BOLTS DO NOT EXTEND PAST INSIDE FACE OF HOUSING AND RUB ON COUPLING ASS'Y.

THIS DRAWING IS THE PROPERTY OF HAYES MFG. INC. AND IS LOANED SUBJECT TO THE CONDITION THAT IT SHALL NOT BE REPRODUCED, COPIED, LOANED OR OTHERWISE DISPOSED OF, DIRECTLY OR INDIRECTLY. IT SHALL BE USED AS A MEANS OF REFERENCE TO WORK FURNISHED BY THIS COMPANY ONLY AND IS NOT TO BE SUBMITTED TO OUTSIDE PARTIES FOR EXAMINATION WITHOUT OUR CONSENT.

SYMBOLS	DET.	PART NUMBER	DESCRIPTION	QTY.
<ul style="list-style-type: none"> — FLATNESS — STRAIGHTNESS — ANGULARITY — SQUARENESS — PARALLELISM — CONCENTRICITY — TRUE POSITION — ROUNDNESS — CIRCULAR RUN OUT — TOTAL RUN OUT — CYLINDRICITY — FINISH 	DO NOT SCALE DRAWING TOLERANCES UNLESS OTHERWISE SPECIFIED MAXIMUM ANGLE ±1/2° FRACTION ±1/32 DECIMAL .00 ±.01 .000 ±.005 .0000 ±.0005			
- UNLESS OTHERWISE SPECIFIED - REMOVE FIRST THREAD ON ALL TAPPED HOLES BREAK ALL SHARP CORNERS .010 TO .020 STAMP OR MARK DRAWING NO.		DRAWN BY SIETING CHECKED BY RJH	DATE 07-28-03 SCALE	DRAWING NO. 890020 SHEET OF REV.