

REV	DATE	CHANGE DESCRIPTION	MOD.BY	CK1	CK2

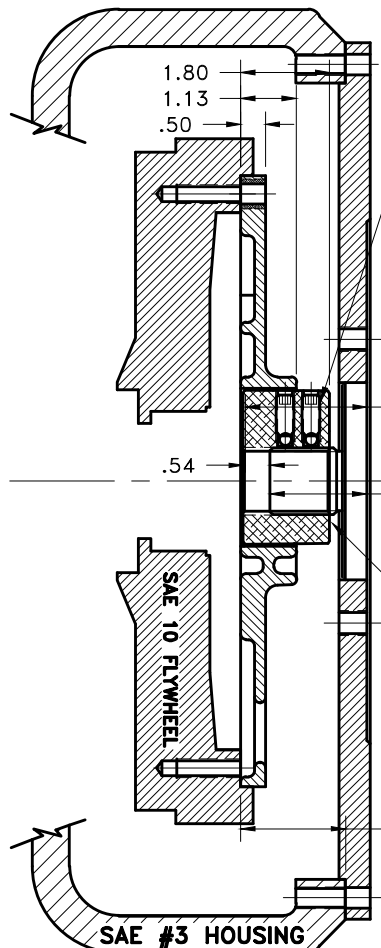

**(2) 3/8" SET SCREWS
TORQUE BOTH TO 25
FT. LBS USING
TORQUE WRENCH AT
FINAL INSTALLATION**

HC3-204
SPLINE DATA
W35x2x16x9H
16 TEETH
35mm MAJOR

2.13
BACKSET

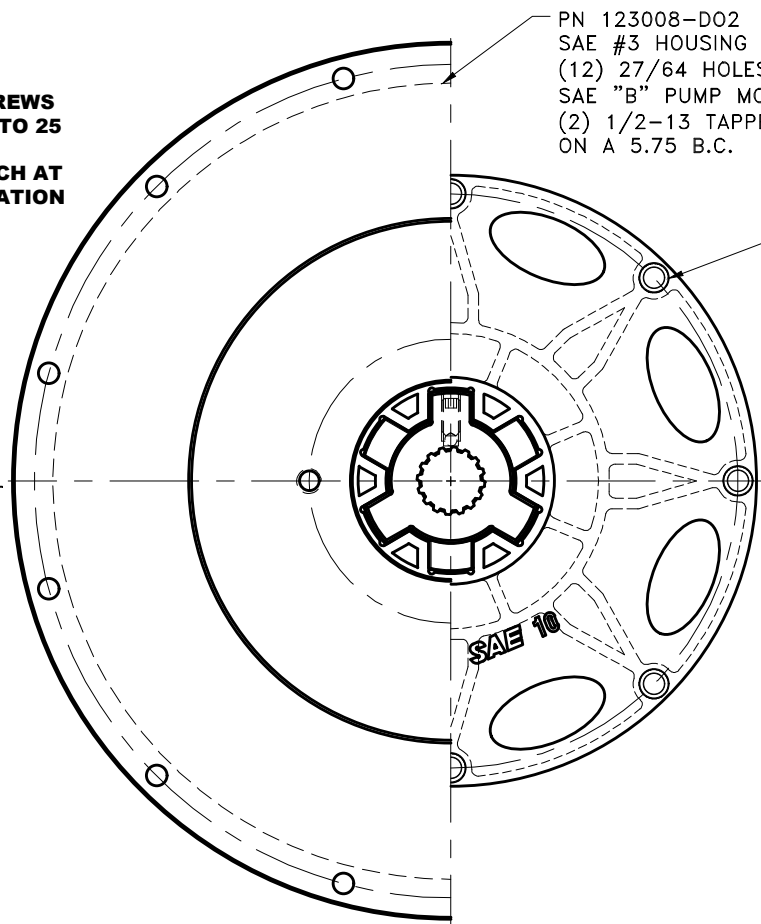

PN 123008-D02
SAE #3 HOUSING MOUNT, 16.13 PILOT
(12) 27/64 HOLES ON A 16.88 B.C.
SAE "B" PUMP MOUNT, 4.00 PILOT
(2) 1/2-13 TAPPED HOLES
ON A 5.75 B.C.

C-010
S.A.E. 10 FIBERGLASS REINFORCED
NYLON DRIVE PLATE
(8) .416 HOLES EQ.
SPACED ON A 11.625 B.C.
"C" SERIES DRIVE

IMPORTANT INSTALLATION NOTE!!!!
**IMPROPER INSTALLATION OF HUB COULD CAUSE
PREMATURE WEAR AND OR FAILURE.**

**IF YOU HAVE QUESTIONS CONCERNING LOCATION
OF METAL HUB ON PUMP SHAFT PLEASE CONTACT
DISTRIBUTOR OR FACTORY FOR FURTHER
INFORMATION**

**BOTH HUB SET SCREWS MUST BE PROPERLY
TORQUED TO 25 FT.LBS. USING TORQUE WRENCH.
PLEASE CONTACT DISTRIBUTOR OR FACTORY FOR
ANY FURTHER QUESTIONS.**

**NOTE: THIS STEP IS IMPORTANT TO
ENSURE FULL SPLINE ENGAGEMENT.**

- 1) PRESET HUB ON SHAFT AS SHOWN.
- 2) IF YOUR PUMP SHAFT VARIES FROM THE DRAWN SHAFT LENGTH, CONTACT FACTORY FOR RECOMMENDATIONS.
- 3) **TORQUE BOTH SET SCREWS TO 25 FT.LBS. USING TORQUE WRENCH.**
- 4) **SHAFT SHOULD HAVE FULL SPLINE ENGAGEMENT INTO HUB, IF NOT CONTACT FACTORY FOR RECOMMENDATIONS (231) 879-3372.**

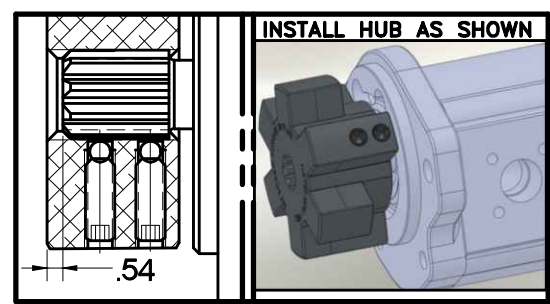

SET HUB AS SHOWN

**"C" SERIES TORQUE RANGE
65-200 HP**

DET.	PART NUMBER	DESCRIPTION	QTY.
3	123008-D02	PUMP MOUNT PLTE	1
2	HC3-204	C SERIES HEX~FLX HUB	1
1	C-010	SAE 10 HEX~FLX DRIVE PLATE	1

SYMBOLS		DET.	PART NUMBER	DESCRIPTION	QTY.
	FLATNESS	DO NOT SCALE DRAWING			
	STRAIGHTNESS	TOLERANCES UNLESS OTHERWISE SPECIFIED			
	ANGULARITY	1/32" MAXIMUM			
	PERPENDICULARITY	ANGLE ±1/2°			
	PARALLELISM	FRACTION ±1/32			
	CONCENTRICITY	DECIMAL .00 ±.01			
	TRUE POSITION	TOTAL RUN OUT .000 ±.005			
	ROUNDNESS	CYLINDRICITY .0000 ±.0005			
	CIRCULAR RUN OUT	FINISH			
	TOTAL RUN OUT	CLASS			
	CYLINDRICITY	MAKE: <input type="checkbox"/> BUY: <input type="checkbox"/>			
	FINISH	DRAWN BY LAWSON			
		DATE 4-25-2017		DRAWING NO. C-010-HC3-204-D02	
		CHECKED BY RJH		SCALE SHEET OF REV.	



TITLE
HEX~FLX "C" SERIES 2 PIECE COUPLING

THIS DRAWING IS THE PROPERTY OF HAYES MFG. INC. AND IS LOANED SUBJECT TO THE CONDITION THAT IT SHALL NOT BE REPRODUCED, COPIED, LOANED OR OTHERWISE DISPOSED OF, DIRECTLY OR INDIRECTLY. IT SHALL BE USED AS A MEANS OF REFERENCE TO WORK FURNISHED BY THIS COMPANY ONLY AND IS NOT TO BE SUBMITTED TO OUTSIDE PARTIES FOR EXAMINATION WITHOUT OUR CONSENT.