

REV	DATE	CHANGE DESCRIPTION	MOD.BY	CK1	CK2
B	08/28/2014	REMOVED SNAP RING	LAWSON		

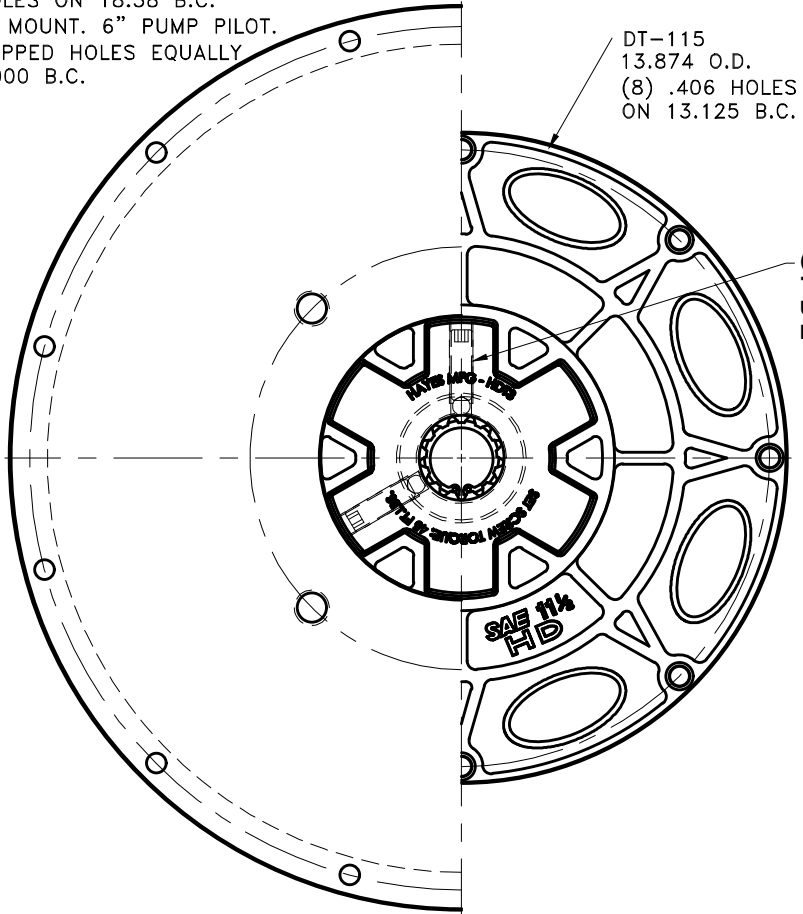
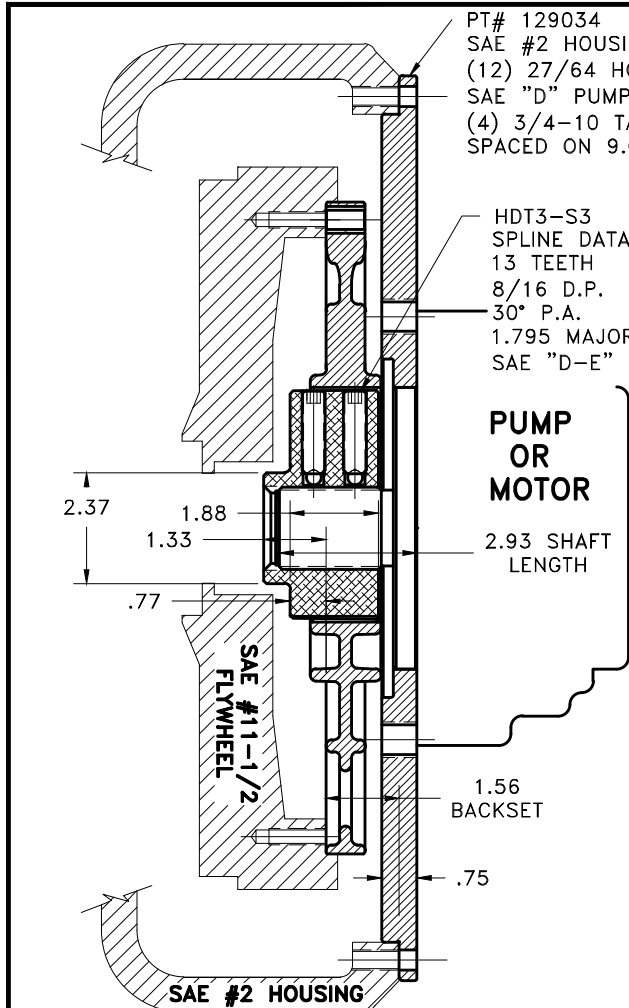

(4) 1/2" SET SCREWS  
TORQUE BOTH TO 45 FT. LBS  
USING TORQUE WRENCH AT  
FINAL INSTALLATION

**DT TORQUE RANGE**  
NOMINAL: 1,300 FT.LBS  
MAX: 3,300 FT.LBS  
NOMINAL: 1,800 NM  
MAX: 4,500 NM

**NOTE: THIS STEP IS IMPORTANT TO ENSURE FULL SPLINE ENGAGEMENT.**

- 1) PRESET HUB ON SHAFT AS SHOWN.
- 2) IF YOUR PUMP SHAFT VARIES FROM THE DRAWN SHAFT LENGTH, CONTACT FACTORY FOR RECOMMENDATIONS.
- 3) **TORQUE (4) SET SCREWS TO 45 FT.LBS. USING TORQUE WRENCH.**
- 4) **SHAFT SHOULD HAVE FULL SPLINE ENGAGEMENT INTO HUB, IF NOT CONTACT FACTORY FOR RECOMMENDATIONS (231) 879-3372.**

THIS DRAWING IS THE PROPERTY OF HAYES MFG. INC. AND IS LOANED SUBJECT TO THE CONDITION THAT IT SHALL NOT BE REPRODUCED, COPIED, LOANED OR OTHERWISE DISPOSED OF, DIRECTLY OR INDIRECTLY. IT SHALL BE USED AS A MEANS OF REFERENCE TO WORK FURNISHED BY THIS COMPANY ONLY AND IS NOT TO BE SUBMITTED TO OUTSIDE PARTIES FOR EXAMINATION WITHOUT OUR CONSENT.

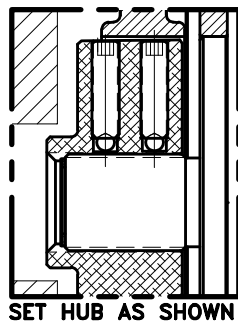

**IMPORTANT INSTALLATION NOTE!!!!**

IMPROPER INSTALLATION OF HUB COULD CAUSE PREMATURE WEAR AND OR FAILURE.

IF YOU HAVE QUESTIONS CONCERNING LOCATION OF METAL HUB ON PUMP SHAFT PLEASE CONTACT DISTRIBUTOR OR FACTORY FOR FURTHER INFORMATION.

**ALL (4) SET SCREWS MUST BE PROPERLY TORQUED TO 45 FT.LBS. USING TORQUE WRENCH. PLEASE CONTACT DISTRIBUTOR OR FACTORY FOR ANY FURTHER QUESTIONS.**

DET.	PART NUMBER	DESCRIPTION	QTY.
3	129034	PUMP MOUNT PLATE	1
2	HDT3-S3	DT SERIES DRIVE HUB	1
1	DT-115	SAE 11 1/2 HEX~FLX PLATE	1

SYMBOLS		DET.	PART NUMBER	DESCRIPTION	QTY.
	FLATNESS	<p>DO NOT SCALE DRAWING</p> <p>TOLERANCES UNLESS OTHERWISE SPECIFIED</p> <p>1/32" MAXIMUM</p> <p>ANGLE ±1/2°</p> <p>FRACTION ±1/32</p> <p>DECIMAL .00 ±.01</p> <p>TOTAL RUN OUT .000 ±.005</p> <p>.0000 ±.0005</p> <p>FINISH</p>			
	STRAIGHTNESS				
	ANGULARITY				
	PERPENDICULARITY				
	PARALLELISM				
	CONCENTRICITY				
	TRUE POSITION				
	ROUNDNESS				
	CIRCULAR RUN OUT				
	CYLINDRICITY				
CLASS		MAKE: <input type="checkbox"/>	BUY: <input type="checkbox"/>	DRAWN BY	
DESCRIPTION		CHECKED BY		DATE	
		R/JH		09-21-2009	
		SCALE		DRAWING NO.	
				DT-115-HDT3-S3-CSP1	
				SHEET OF REV.	