

REV	DATE	CHANGE DESCRIPTION	MOD. BY	CK1	CK2
F	02/23/2006	CHANGED TO BOLTED INSERTS.	ZS	HM	RJH

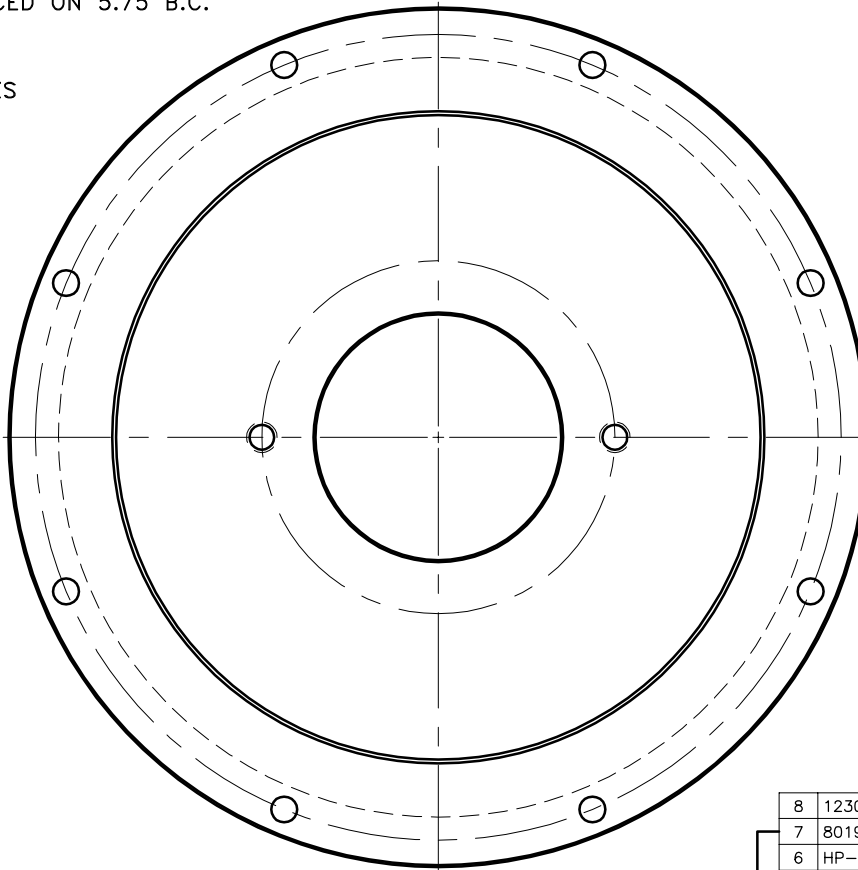
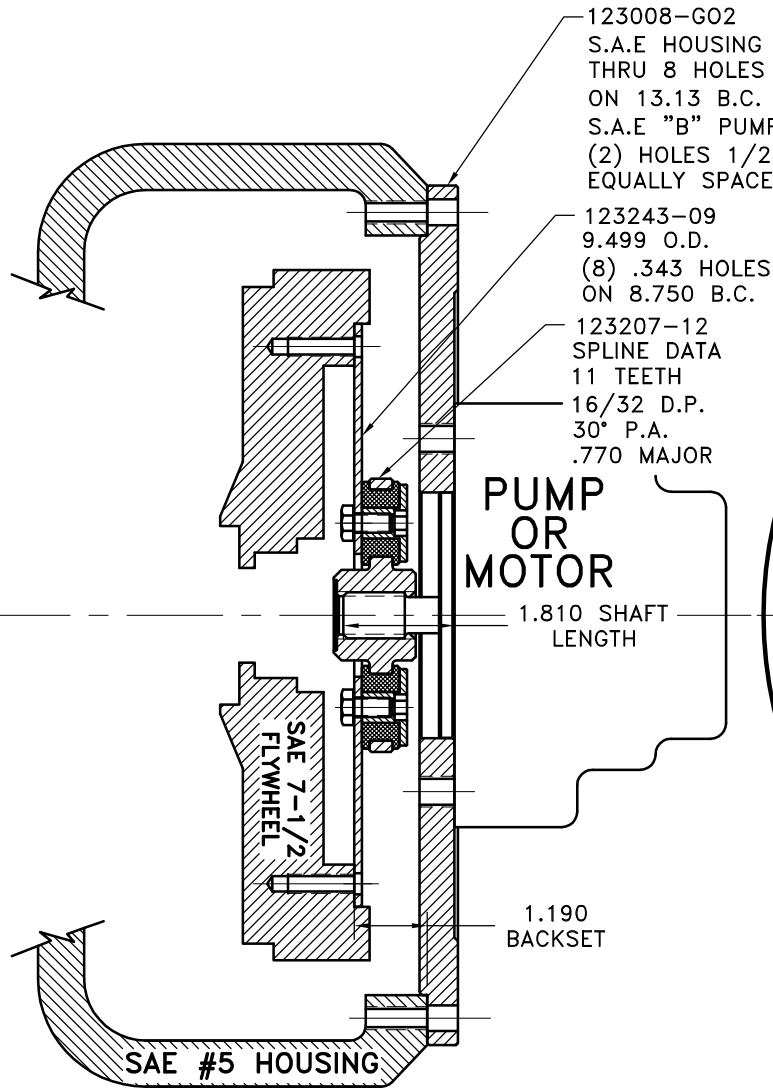

COUPLING ASS'Y #123338

UP TO 50 H.P.

8	123008-G02	PUMP MTG. PLATE	1
7	801912	GREASE	1
6	HP-1125-S-32	HUBBARD PLUG	1
5	HX100	5/16-24 x 5/8" HHB	6
4	123729-01	THREADED BUSHINGS	6
3	H52500	NEOPRENE INSERT	6
2	123207-12	COUPLING HUB	1
1	123243-09	FLYWHEEL PLATE	1

SYMBOLS	DET.	PART NUMBER	DESCRIPTION	QTY.
FLATNESS STRAIGHTNESS ANGULARITY SQUARENESS PARALLELISM CONCENTRICITY TRUE POSITION ROUNDNESS CIRCULAR RUN OUT TOTAL RUN OUT CYLINDRICITY FINISH	DO NOT SCALE DRAWING TOLERANCES UNLESS OTHERWISE SPECIFIED MAXIMUM ANGLE ±1/2° FRACTION ±1/32 DECIMAL .00 ±.01 .000 ±.005 .0000 ±.0005			
- UNLESS OTHERWISE SPECIFIED - REMOVE FIRST THREAD ON ALL TAPPED HOLES BREAK ALL SHARP CORNERS .010 TO .020 STAMP OR MARK DRAWING NO.		DRAWN BY SIETING	DATE 09-18-89	DRAWING NO. 123079 SHEET OF REV.

THIS DRAWING IS THE PROPERTY OF HAYES MFG. INC. AND IS LOANED SUBJECT TO THE CONDITION THAT IT SHALL NOT BE REPRODUCED, COPIED, LOANED OR OTHERWISE DISPOSED OF, DIRECTLY OR INDIRECTLY. IT SHALL BE USED AS A MEANS OF REFERENCE TO WORK FURNISHED BY THIS COMPANY ONLY AND IS NOT TO BE SUBMITTED TO OUTSIDE PARTIES FOR EXAMINATION WITHOUT OUR CONSENT.