

REV	DATE	CHANGE DESCRIPTION	MOD BY	CHK1	CHK2
F	03/15/2006	CHANGED COUPLING ONLY #	ZS		

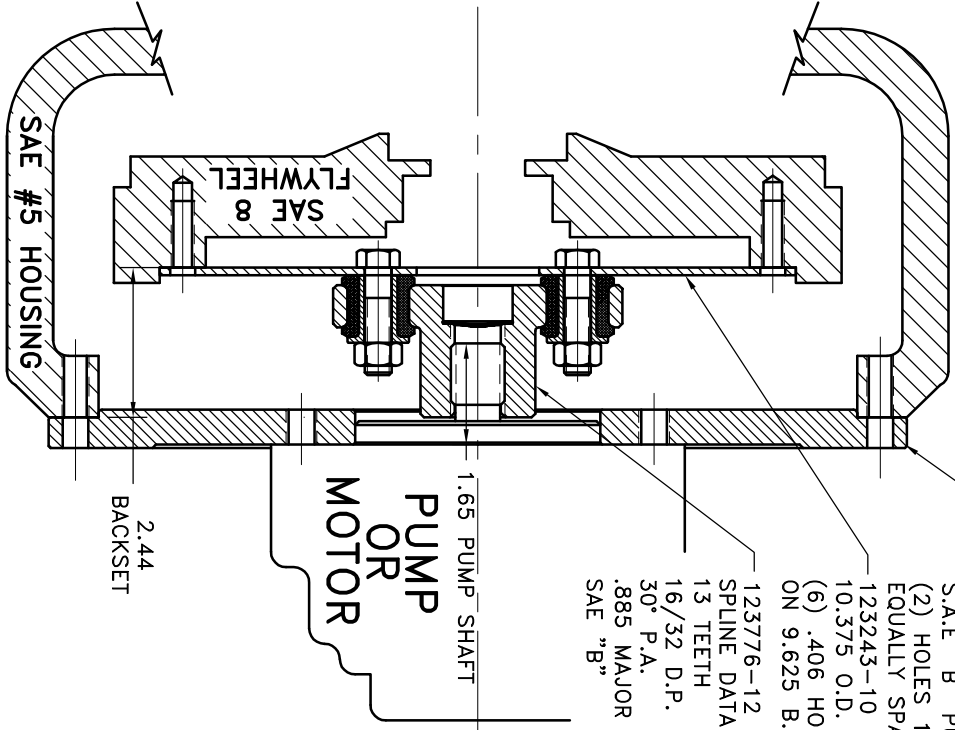

- 123008-G02
- S.A.E HOUSING MOUNT 27/64 DRILL THRU 8 HOLES EQUALLY SPACED ON 13.13 B.C. 4" PUMP PILOT S.A.E "B" PUMP MOUNT.
- (2) HOLES 1/2-13 TAPPED HOLES EQUALLY SPACED ON 5.75 B.C.
- 123243-10
- 10.375 O.D.
- (6) .406 HOLES ON 9.625 B.C.
- 123776-12
- SPLINE DATA
- 13 TEETH
- 16/32 D.P.
- 30° P.A.
- .885 MAJOR SAE "B"

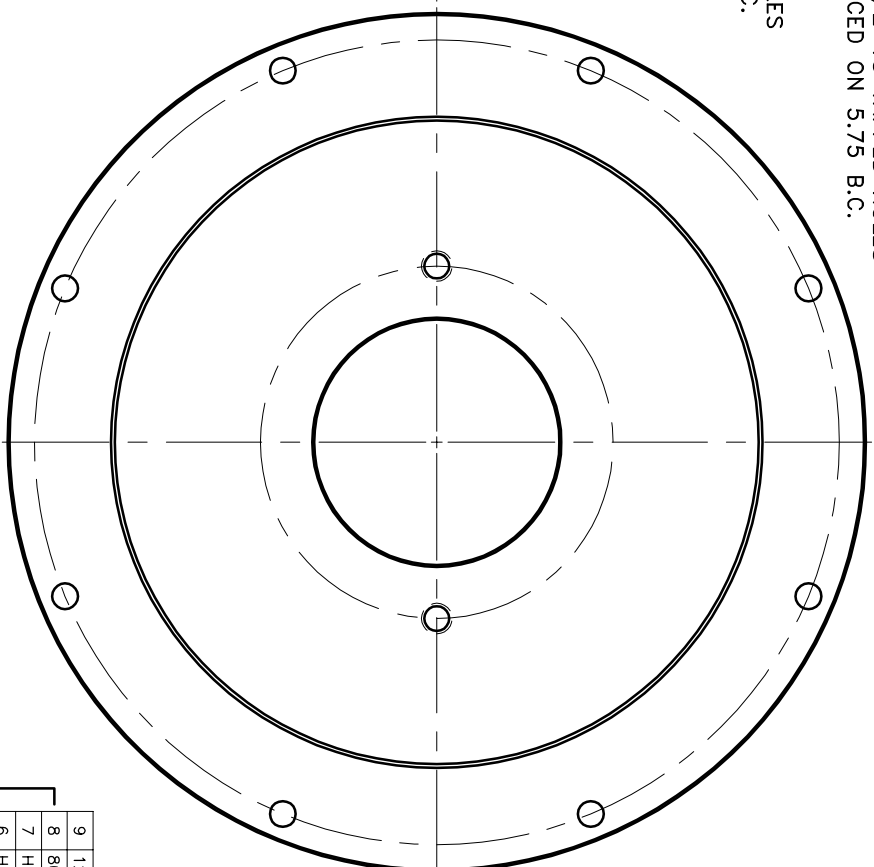

COUPLING ASS'Y #123961

UP TO 65 HP

QTY.	PART NUMBER	DESCRIPTION
1	123008-G02	PUMP MOUNT PLATE
1	801912	GREASE
1	7 HP-937-S-32	HUBBARD PLUG
6	6 HX230	7/16-20x1-3/4 BOLT
6	5 N250	7/16-20 NUT
6	4 123000-00	STEEL BUSHING
6	3 H62500	NEOPRENE INSERT
1	2 123776-12	COUP HUB [1.31 16/32\3.250]
1	1 123243-10	FLYWHEEL PLATE [8\3.250]

SYMBOLS

- FLATNESS UNLESS SPECIFIED
- ANGULARITY UNLESS SPECIFIED
- PARALLELISM UNLESS SPECIFIED
- PERPENDICULARITY UNLESS SPECIFIED
- CONCENTRICITY UNLESS SPECIFIED
- TAPER UNLESS SPECIFIED
- ROUNDNESS UNLESS SPECIFIED
- CIRCULAR RUN OUT UNLESS SPECIFIED
- TOTAL RUN OUT UNLESS SPECIFIED
- CYLINDRICITY UNLESS SPECIFIED
- FINISH UNLESS OTHERWISE SPECIFIED -
- REMOVE FIRST THREE DIGITS
- BREAK ALL SHARP CORNERS .010 TO .020
- STAMP OR MARK DRAWING NO.

DO NOT SCALE DRAWING

UNLESS OTHERWISE SPECIFIED -

ANGLE ±1/32

FRACTION ±1/32

DECIMAL ±.005

±.000 ±.0005

MAXIMUM

MINIMUM

WIRE

HAYES MANUFACTURING INC. ®

THE FLYWHEEL COUPLING ASSY WITH PUMP MOUNT PLATE

DRAWN BY	DATE	DRAWING NO.
CHECKED BY	8-08-89	123164
SCALE		SHEET OF REV.

THIS DRAWING IS THE PROPERTY OF HAYES MFG. INC. AND IS LOANED SUBJECT TO THE CONDITION THAT IT SHALL NOT BE REPRODUCED, COPIED, EITHER WHOLLY OR IN PART, OR TRANSMITTED IN ANY MANNER. IT SHALL BE USED AS A MEANS OF REFERENCE TO WORK FURNISHED BY THIS COMPANY ONLY AND IS NOT TO BE SUBMITTED TO OUTSIDE PARTIES FOR EXAMINATION WITHOUT OUR CONSENT.