

REV	DATE	CHANGE DESCRIPTION	MOD BY	CK1	CK2

3/8-16 TAPPED HOLES
(12) EQ. SPACED ON
A 15.00" B.C.

(8) 11/16" C'BORE
13/32 HOLES EQ. SPACED
ON A 13.13" B.C.

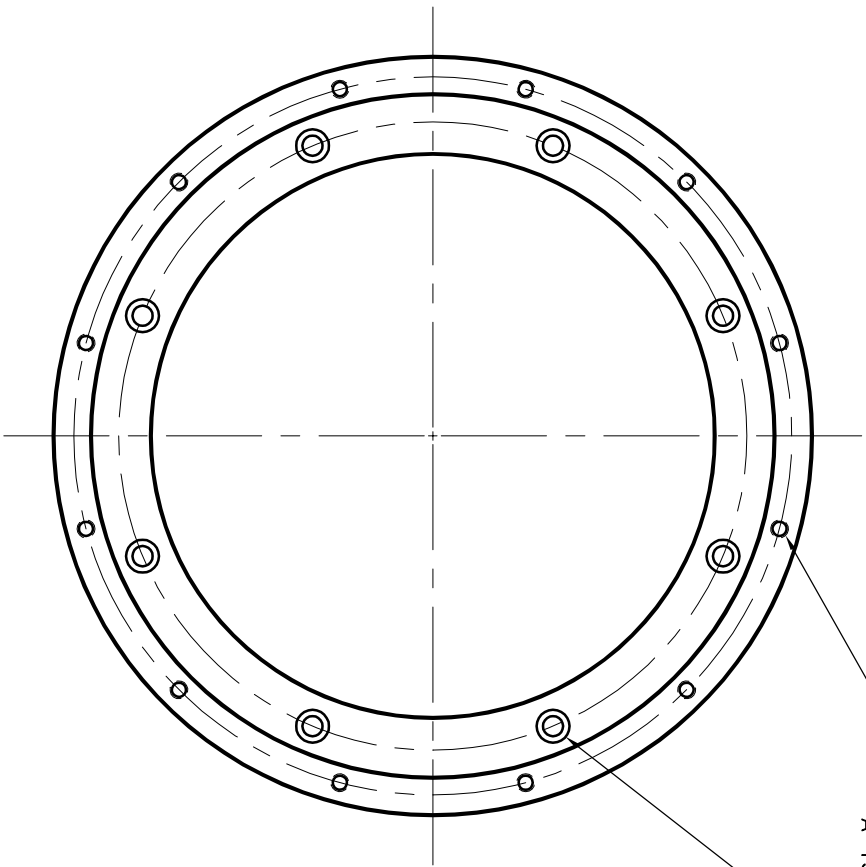
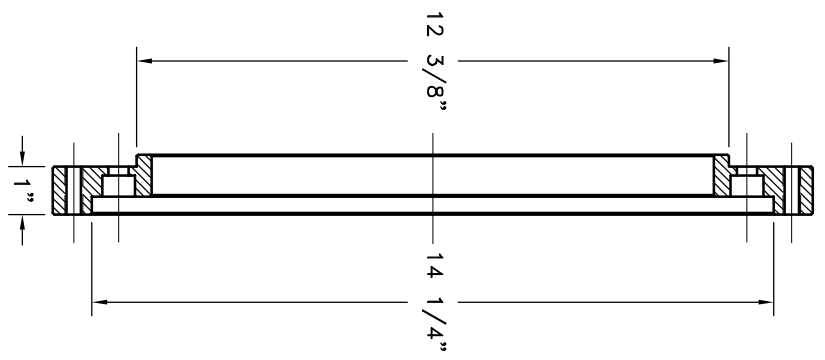

SAE #5 TO #4 x 1" OFFSET

SYMBOLS		DET.	PART NUMBER	DESCRIPTION	QTY.
	FLATNESS	DO NOT SCALE			
	FINISH	DRAWING			
	ANGULARITY	UNLESS OTHERWISE SPECIFIED -			
	PARALLELISM	MAXIMUM			
	PERPENDICULARITY	ANGLE ±1/2°			
	PROFILE	FORM DEPENDENT			
	ROUNDNESS	±.01			
	CIRCULAR RUN OUT	±.005			
	TOTAL RUN OUT	±.005			
	CYLINDRICITY	±.0005			
- UNLESS OTHERWISE SPECIFIED - MAKE FIRST THREE BREAK ALL SHARP CORNERS .010 TO .020 STAMP OR MARK DRAWING NO.					
TITLE		DRAWN BY	DATE	DRAWING NO.	
HOUSING ADAPTER		ALUMINUM	06-21-06	26-00304	
MATERIAL		CHECKED BY	SCALE	SHEET	OF
ALUMINUM		RJH		26-00304	
DRAWING NO.		DATE		SHEET	
26-00304		06-21-06		26-00304	
OF		REV.		REV.	



THIS DRAWING IS THE PROPERTY OF HAYES MFG. INC. AND IS LOANED TO YOU FOR THE EXCLUSIVE PURPOSE OF IDENTIFYING DEFECTS. IT SHALL BE USED AS A MEANS OF REFERENCE TO WORK FURNISHED BY THIS COMPANY ONLY, AND IS NOT TO BE SUBMITTED TO OUTSIDE PARTIES FOR EXAMINATION WITHOUT OUR CONSENT.