

REV	DATE	CHANGE DESCRIPTION	MOD. BY	CK1	CK2

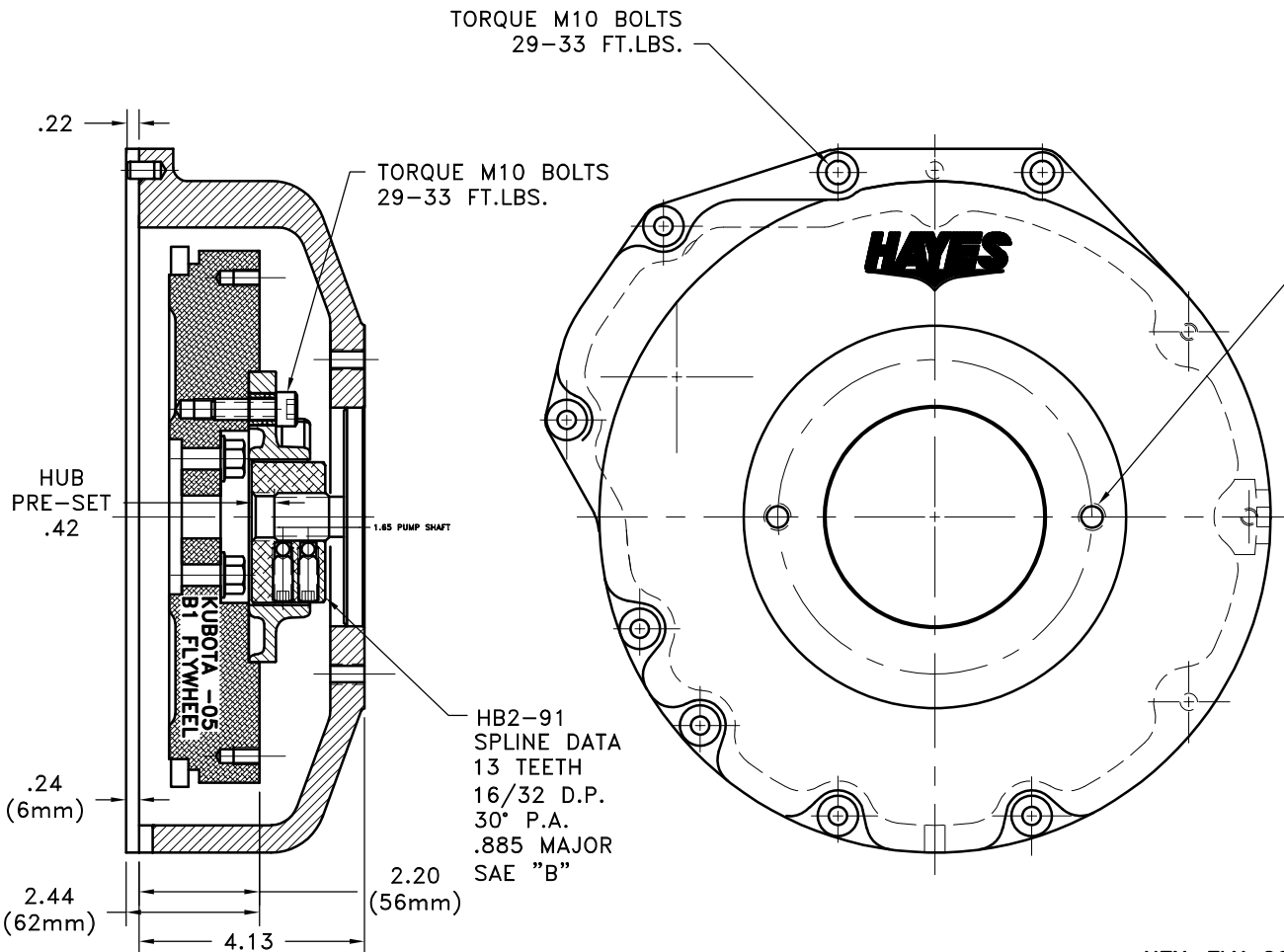

S.A.E. B 2-BOLT MOUNT
4.00" PILOT
(2) 1/2-13 TAPPED HOLES
EQ. SPACED ON A 5.75 B.C.

NOTES:
1. HOUSING FOR KUBOTA ENGINES
D-905, D1005-B, D1105-B, V1205-B,
V1305-P, AND V1505-B.

IMPORTANT INSTALLATION NOTE!!!!
**IMPROPER INSTALLATION OF HUB COULD CAUSE
PREMATURE WEAR AND OR FAILURE.**

IF YOU HAVE QUESTIONS CONCERNING LOCATION
OF METAL HUB ON PUMP SHAFT PLEASE CONTACT
DISTRIBUTOR OR FACTORY FOR FURTHER
INFORMATION

**BOTH HUB SET SCREWS MUST BE PROPERLY
TORQUED TO 25 FT.LBS. USING TORQUE WRENCH.**
**PLEASE CONTACT DISTRIBUTOR OR FACTORY FOR
ANY FURTHER QUESTIONS.**

**NOTE: THIS STEP IS IMPORTANT TO
ENSURE FULL SPLINE ENGAGEMENT.**

- 1) PRESET HUB ON SHAFT AS SHOWN.
- 2) IF YOUR PUMP SHAFT VARIES FROM THE DRAWN
SHAFT LENGTH, CONTACT FACTORY FOR
RECOMMENDATIONS.
- 3) **TORQUE BOTH SET SCREWS TO 25 FT.LBS. USING
TORQUE WRENCH.**
- 4) SHAFT SHOULD HAVE FULL SPLINE ENGAGEMENT INTO
HUB, IF NOT CONTACT FACTORY FOR
RECOMMENDATIONS (231) 879-3372.

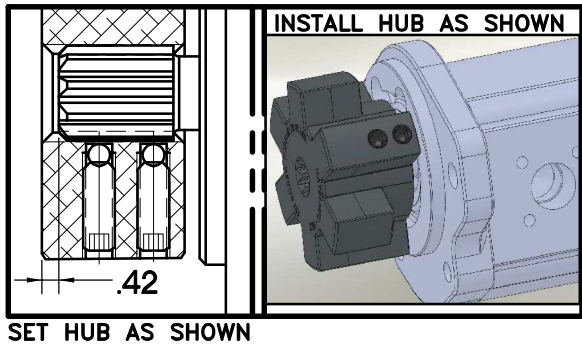

**HEX~FLX COUPLING ASS'Y
B-S05-HB2-91**

5	952182	BOLT KIT	1
4	SD200X5/16X1/2	5/16 X 1/2 SPRING DOWEL	2
3	952055-02	HOUSING	1
2	HB2-91	HEX~FLX HUB	1
1	B-S05	HEX~FLX DRIVE PLATE	1

SYMBOLS		DET.	PART NUMBER	DESCRIPTION	QTY.
DO NOT SCALE DRAWING TOLERANCES UNLESS OTHERWISE SPECIFIED 125 MAXIMUM ANGLE ±1/2" FRACTION ±1/32 DECIMAL .00 ±.01 .000 ±.005 .0000 ±.0005					
CLASS KUBOTA		MAKE: <input checked="" type="checkbox"/> BUY: <input type="checkbox"/>		DRAWN BY SIETING	
DESCRIPTION KB05,13T16/32,B2		DATE 05-03-07		DRAWING NO. 006-0-HB2-91-B2	
FINISH		CHECKED BY RJH		SCALE SHEET OF REV.	

THIS DRAWING IS THE PROPERTY OF HAYES MFG. INC. AND IS LOANED
SUBJECT TO THE CONDITION THAT IT SHALL NOT BE REPRODUCED,
COPIED, LOANED OR OTHERWISE DISPOSED OF, DIRECTLY OR INDIRECTLY.
IT SHALL BE USED AS A MEANS OF REFERENCE TO WORK FURNISHED BY
THIS COMPANY ONLY AND IS NOT TO BE SUBMITTED TO OUTSIDE PARTIES
FOR EXAMINATION WITHOUT OUR CONSENT.