

REV	DATE	CHANGE DESCRIPTION	MOD. BY	CK1	CK2
A	01/11/2017	CHANGED BOLT KIT	BSL	JM	ML

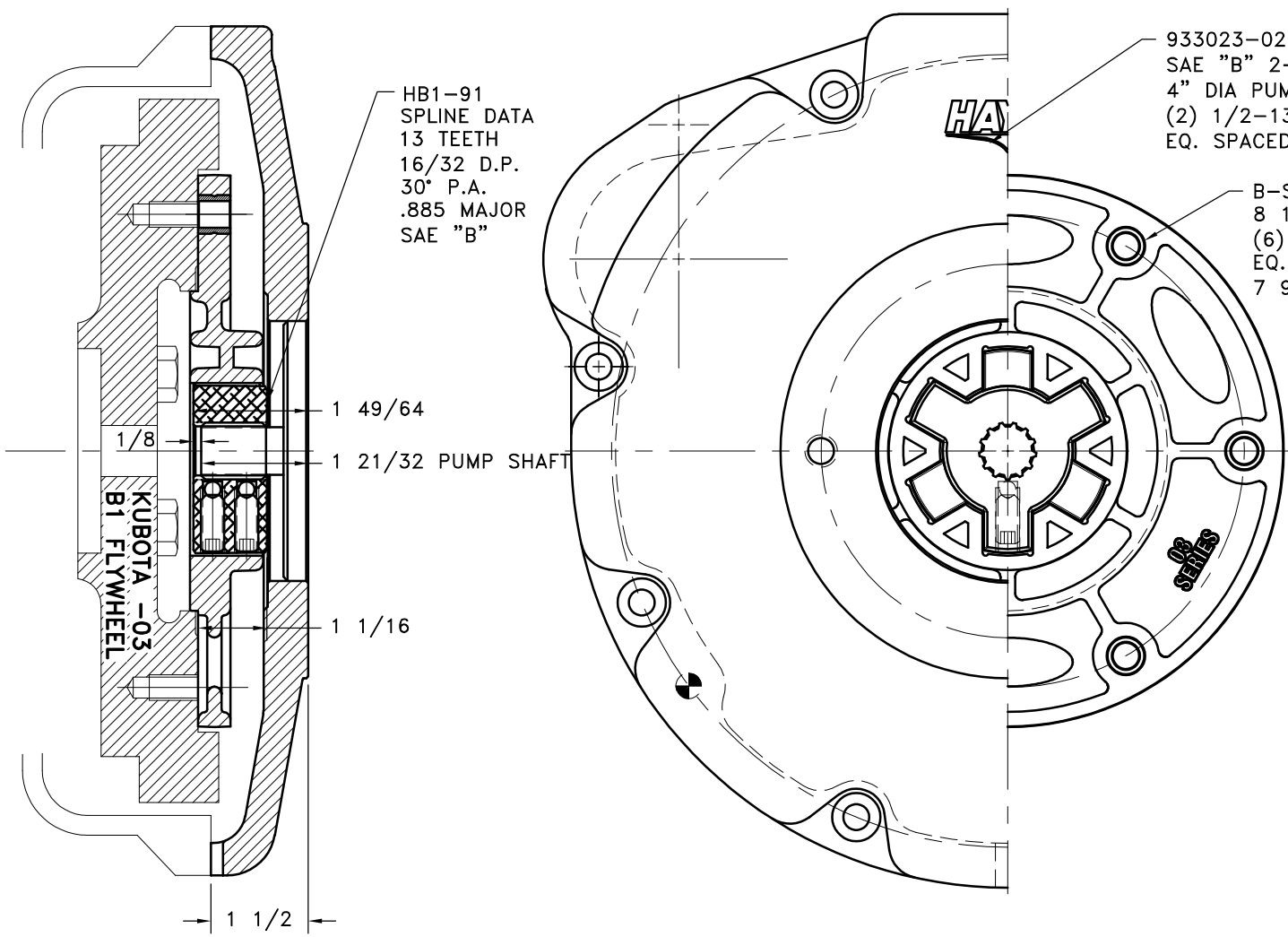

NOTE: INSTALL 2 DOWEL PINS

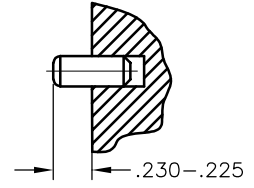

IMPORTANT INSTALLATION NOTE!!!!
IMPROPER INSTALLATION OF HUB COULD CAUSE
PREMATURE WEAR AND OR FAILURE.

IF YOU HAVE QUESTIONS CONCERNING LOCATION
OF METAL HUB ON PUMP SHAFT PLEASE CONTACT
DISTRIBUTOR OR FACTORY FOR FURTHER
INFORMATION

**BOTH HUB SET SCREWS MUST BE PROPERLY
TORQUED TO 25 FT.LBS. USING TORQUE WRENCH.**
PLEASE CONTACT DISTRIBUTOR OR FACTORY FOR
ANY FURTHER QUESTIONS.

NOTE:

- HOUSING FOR KUBOTA ENGINES D1403-B, D1703-B, V1903-B, AND V2203-B.

**ASS'Y WORKS WITH
FLYWHEELS: C-1(16414-25111) &
C-4(19629-25113)
HOUSINGS: D-9(19004-04611) &
D-8(19077-04611)**

**NOTE: THIS STEP IS IMPORTANT TO
ENSURE FULL SPLINE ENGAGEMENT.**

- PRESET HUB ON SHAFT AS SHOWN.
- IF YOUR PUMP SHAFT VARIES FROM THE DRAWN SHAFT LENGTH, CONTACT FACTORY FOR RECOMMENDATIONS.
- TORQUE BOTH SET SCREWS TO 25 FT.LBS. USING TORQUE WRENCH.**
- SHAFT SHOULD HAVE FULL SPLINE ENGAGEMENT INTO HUB, IF NOT CONTACT FACTORY FOR RECOMMENDATIONS (231) 879-3372.

THIS DRAWING IS THE PROPERTY OF HAYES MFG. INC. AND IS LOANED SUBJECT TO THE CONDITION THAT IT SHALL NOT BE REPRODUCED, COPIED, LOANED OR OTHERWISE DISPOSED OF, DIRECTLY OR INDIRECTLY. IT SHALL BE USED AS A MEANS OF REFERENCE TO WORK FURNISHED BY THIS COMPANY ONLY AND IS NOT TO BE SUBMITTED TO OUTSIDE PARTIES FOR EXAMINATION WITHOUT OUR CONSENT.

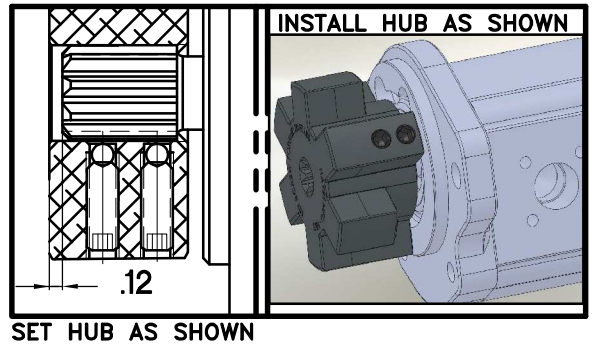

5	933504	BOLT KIT (PRE-ASSEMBLED)	1
4	SD200X10X20	M10 X 20 SPRING DOWEL	2
3	933023-02	HOUSING	1
2	HB1-91	HEX-FLX DRIVE HUB	1
1	B-S03	HEX-FLX DRIVE PLATE	1

SYMBOLS		DET.	PART NUMBER	DESCRIPTION	QTY.
/ FLATNESS - STRAIGHTNESS < ANGLARITY ⊥ PERPENDICULARITY // PARALLELISM ⊙ CONCENTRICITY ⊕ TRUE POSITION ○ ROUNDNESS ⊖ CIRCULAR RUN OUT ⊖ TOTAL RUN OUT ⊖ CYLINDRICITY ✓ FINISH		DO NOT SCALE DRAWING			
TOLERANCES UNLESS OTHERWISE SPECIFIED 125 MAXIMUM ANGLE ±1/2° FRACTION ±1/32 DECIMAL .00 ±.01 .000 ±.005 .0000 ±.0005					
CLASS		TITLE			
KB03		KUBOTA 03 HEX-FLX KIT			
DESCRIPTION		MATERIAL			
KB03,13T16/32,B2					
MAKE: <input checked="" type="checkbox"/>	BUY: <input type="checkbox"/>	DRAWN BY		DATE	DRAWING NO.
		SIETING		08-15-2013	008-0-HB1-91-B2
		CHECKED BY		SCALE	SHEET OF REV.
		RJH			1 OF 1