

REV	DATE	CHANGE DESCRIPTION	MOD. BY	CK1	CK2
A	01/11/2017	CHANGED BOLT KIT	BSL	JM	ML

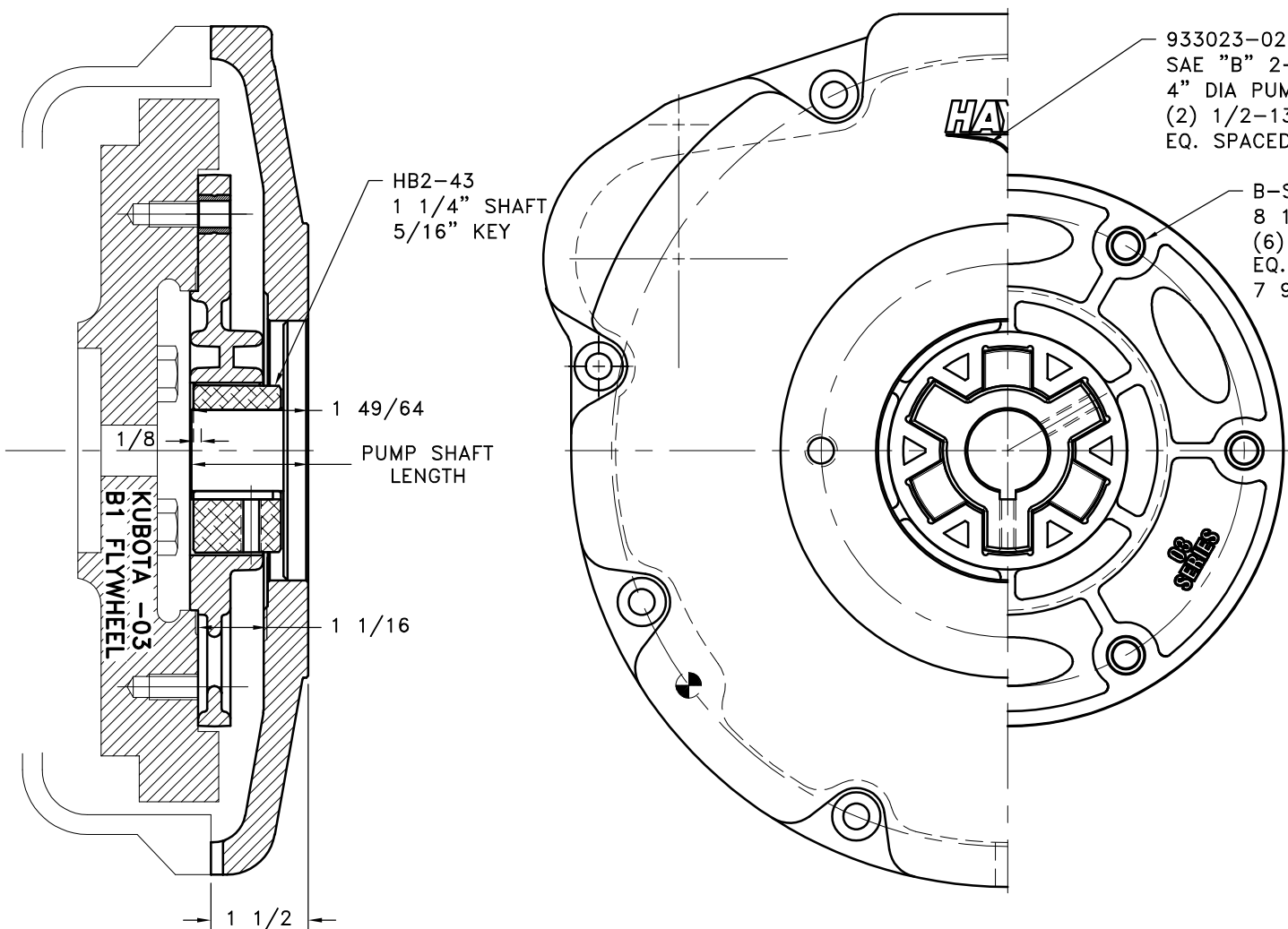

933023-02
SAE "B" 2-BOLT MOUNT
4" DIA PUMP PILOT
(2) 1/2-13 TAPPED HOLES
EQ. SPACED ON 5 3/4 B.C.

B-S03
8 1/2 DIA
(6) 13/32 HOLES
EQ. SPACED ON
7 9/32 B.C.

NOTE: INSTALL 2 DOWEL PINS

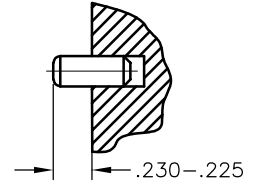

IMPORTANT INSTALLATION NOTE!!!!
IMPROPER INSTALLATION OF HUB COULD CAUSE
PREMATURE WEAR AND OR FAILURE.

IF YOU HAVE QUESTIONS CONCERNING LOCATION
OF METAL HUB ON PUMP SHAFT PLEASE CONTACT
DISTRIBUTOR OR FACTORY FOR FURTHER
INFORMATION

**BOTH HUB SET SCREWS MUST BE PROPERLY
TORQUED TO 25 FT.LBS. USING TORQUE WRENCH.**
PLEASE CONTACT DISTRIBUTOR OR FACTORY FOR
ANY FURTHER QUESTIONS.

NOTE:

- HOUSING FOR KUBOTA ENGINES D1403-B, D1703-B, V1903-B, AND V2203-B.

**ASS'Y WORKS WITH
FLYWHEELS: C-1(16414-25111) &
C-4(19629-25113)
HOUSINGS: D-9(19004-04611) &
D-8(19077-04611)**

NOTE: REMOVE HUB FROM ASS'Y, PRESET HUB ON SHAFT AS SHOWN. **TORQUE BOTH SET SCREWS TO 25 FT.LBS. USING TORQUE WRENCH.** SHAFT SHOULD HAVE A MINIMUM OF 3/4" OF ENGAGEMENT IF NOT CONTACT FACTORY FOR RECOMMENDATIONS (231) 879-3372 TO GET HUB PRESET USE THIS EQUATION:

**PERFORM CALCULATION BELOW:
1.769 - SHAFT LENGTH - HUB PRESET**

IF YOUR ANSWER IS (+) SHAFT IS INSIDE OF HUB, IF YOUR ANSWER IS (-) SHAFT STICKS OUT OF HUB. (SEE BOXES)

**NOTE: THIS STEP IS IMPORTANT TO
ENSURE FULL SHAFT ENGAGEMENT.**

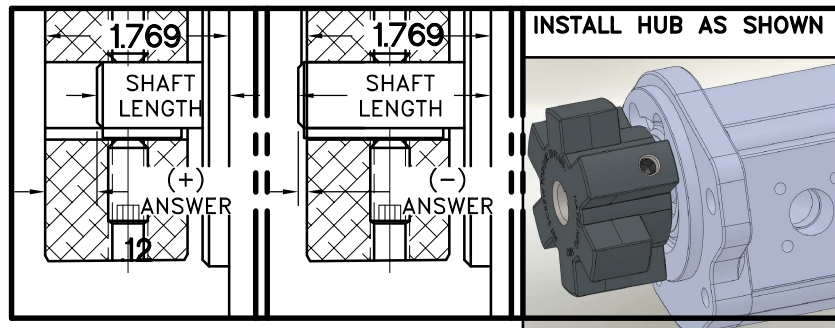

QTY.	DESCRIPTION	PART NUMBER	DET.
1	BOLT KIT (PRE-ASSEMBLED)	933504	5
2	M10 X 20 SPRING DOWEL	SD200X10X20	4
1	HOUSING	933023-02	3
1	HEX-FLX DRIVE HUB	HB1-43	2
1	HEX-FLX DRIVE PLATE	B-S03	1

SYMBOLS		DET.		PART NUMBER		DESCRIPTION		QTY.	
	FLATNESS		DO NOT SCALE DRAWING						
	STRAIGHTNESS	TOLERANCES UNLESS OTHERWISE SPECIFIED							
	ANGULARITY								
	PERPENDICULARITY								
	PARALLELISM								
	CONCENTRICITY								
	TRUE POSITION								
	CIRCULAR RUN OUT								
	TOTAL RUN OUT								
	CYLINDRICITY								
	FINISH								
CLASS		MAKE: <input checked="" type="checkbox"/> BUY: <input type="checkbox"/>		DRAWN BY		DATE		DRAWING NO.	
KUBOTA				SIETING		03-28-2014		008-0-HB2-43-B2	
DESCRIPTION		KBO3,1-1/4x5/16,B2		CHECKED BY		SCALE		SHEET OF REV.	
				RJH				1 OF 1	

THIS DRAWING IS THE PROPERTY OF HAYES MFG. INC. AND IS LOANED SUBJECT TO THE CONDITION THAT IT SHALL NOT BE REPRODUCED, COPIED, LOANED OR OTHERWISE DISPOSED OF, DIRECTLY OR INDIRECTLY. IT SHALL BE USED AS A MEANS OF REFERENCE TO WORK FURNISHED BY THIS COMPANY ONLY AND IS NOT TO BE SUBMITTED TO OUTSIDE PARTIES FOR EXAMINATION WITHOUT OUR CONSENT.