

REV	DATE	CHANGE DESCRIPTION	MOD. BY	CK1	CK2

CUSTOMER TO SUPPLY STARTER PLATE

P/N 942000-02
S.A.E. "B" PUMP MOUNT
4" PILOT
(2) 1/2-13 HOLES ON A 5.75 B.C.

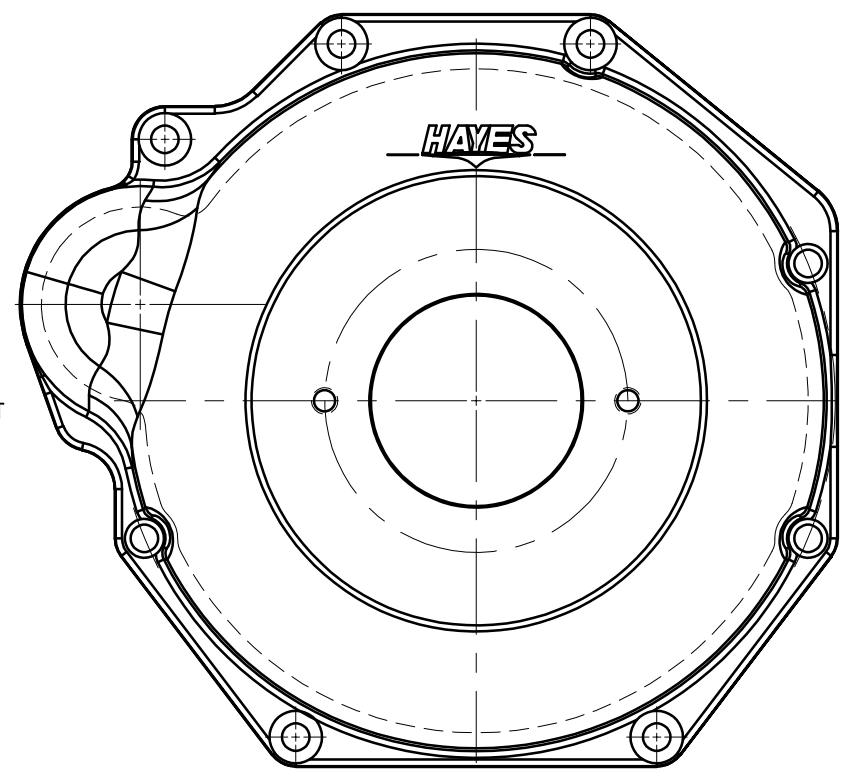
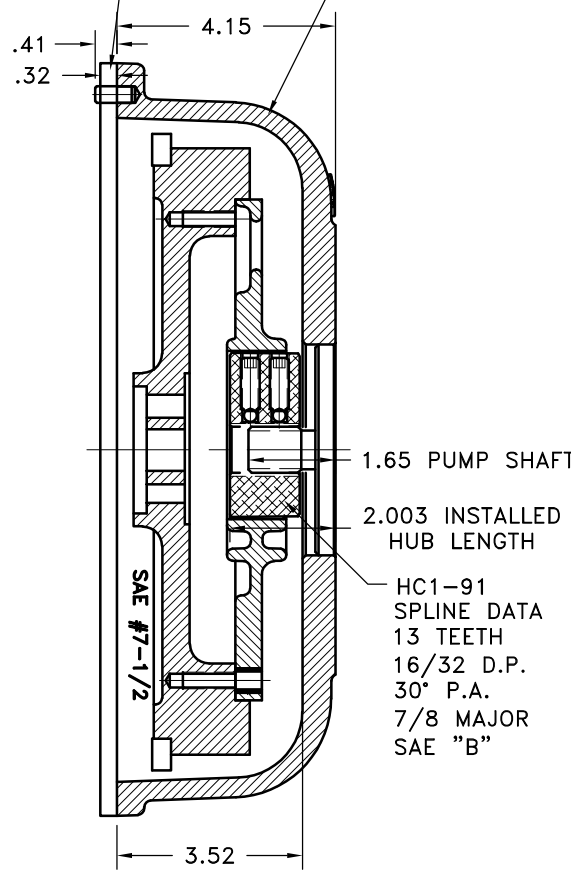

FITS YANMAR ENGINES:
3TNE-78A, 82A, 84, 88, 84(T), 88

FITS ISUZU ENGINES:
3CD1

IMPORTANT INSTALLATION NOTE!!!!
IMPROPER INSTALLATION OF HUB COULD CAUSE PREMATURE WEAR AND OR FAILURE.

IF YOU HAVE QUESTIONS CONCERNING LOCATION OF METAL HUB ON PUMP SHAFT PLEASE CONTACT DISTRIBUTOR OR FACTORY FOR FURTHER INFORMATION

BOTH HUB SET SCREWS MUST BE PROPERLY TORQUED TO 25 FT.LBS. USING TORQUE WRENCH.
PLEASE CONTACT DISTRIBUTOR OR FACTORY FOR ANY FURTHER QUESTIONS.

NOTE: THIS STEP IS IMPORTANT TO ENSURE FULL SPLINE ENGAGEMENT.

- 1) PRESET HUB ON SHAFT AS SHOWN.
- 2) IF YOUR PUMP SHAFT VARIES FROM THE DRAWN SHAFT LENGTH, CONTACT FACTORY FOR RECOMMENDATIONS.
- 3) **TORQUE BOTH SET SCREWS TO 25 FT.LBS. USING TORQUE WRENCH.**
- 4) SHAFT SHOULD HAVE FULL SPLINE ENGAGEMENT INTO HUB, IF NOT CONTACT FACTORY FOR RECOMMENDATIONS (231) 879-3372.

THIS DRAWING IS THE PROPERTY OF HAYES MFG. INC. AND IS LOANED SUBJECT TO THE CONDITION THAT IT SHALL NOT BE REPRODUCED, COPIED, LOANED OR OTHERWISE DISPOSED OF, DIRECTLY OR INDIRECTLY. IT SHALL BE USED AS A MEANS OF REFERENCE TO WORK FURNISHED BY THIS COMPANY ONLY AND IS NOT TO BE SUBMITTED TO OUTSIDE PARTIES FOR EXAMINATION WITHOUT OUR CONSENT.

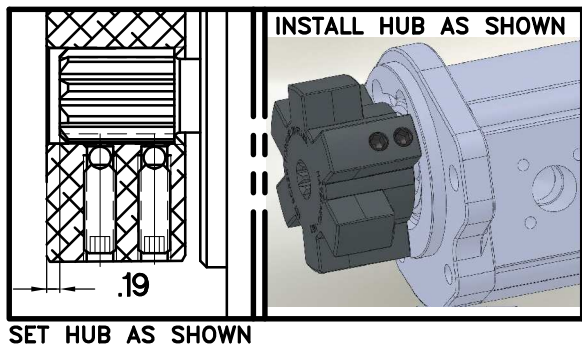

UP TO 50 HP

QTY.	DESCRIPTION	PART NUMBER	DET.
2	5/16x3/4 SPRING DOWEL	SD200X5/16X3/4	5
1	BOLT KIT	942026	4
1	HOUSING	942000-02	3
1	HEX~FLX HUB	HC1-91	2
1	HEX~FLX DRIVE PLATE	C-075	1

SYMBOLS		DET.	PART NUMBER	DESCRIPTION	QTY.
DO NOT SCALE DRAWING TOLERANCES UNLESS OTHERWISE SPECIFIED 125 MAXIMUM ANGLE ±1/2° FRACTION ±1/32 DECIMAL .00 ±.01 .000 ±.005 .0000 ±.0005					
CLASS YANMAR DESCRIPTION YNM3TNE, 13T16/32,B2		MAKE: <input checked="" type="checkbox"/>	BUY: <input type="checkbox"/>	HAYES MANUFACTURING INC. ® TITLE HEX~FLX FLYWHEEL COUPLING WITH HOUSING MATERIAL	DRAWN BY SIETING CHECKED BY RJH
DATE 08-19-2009 SCALE		DRAWING NO. 037-0-HC1-91-B2 SHEET OF REV.			