

REV	DATE	CHANGE DESCRIPTION	MOD.BY	CK1	CK2

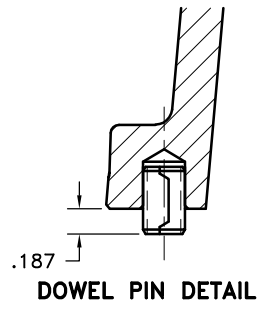
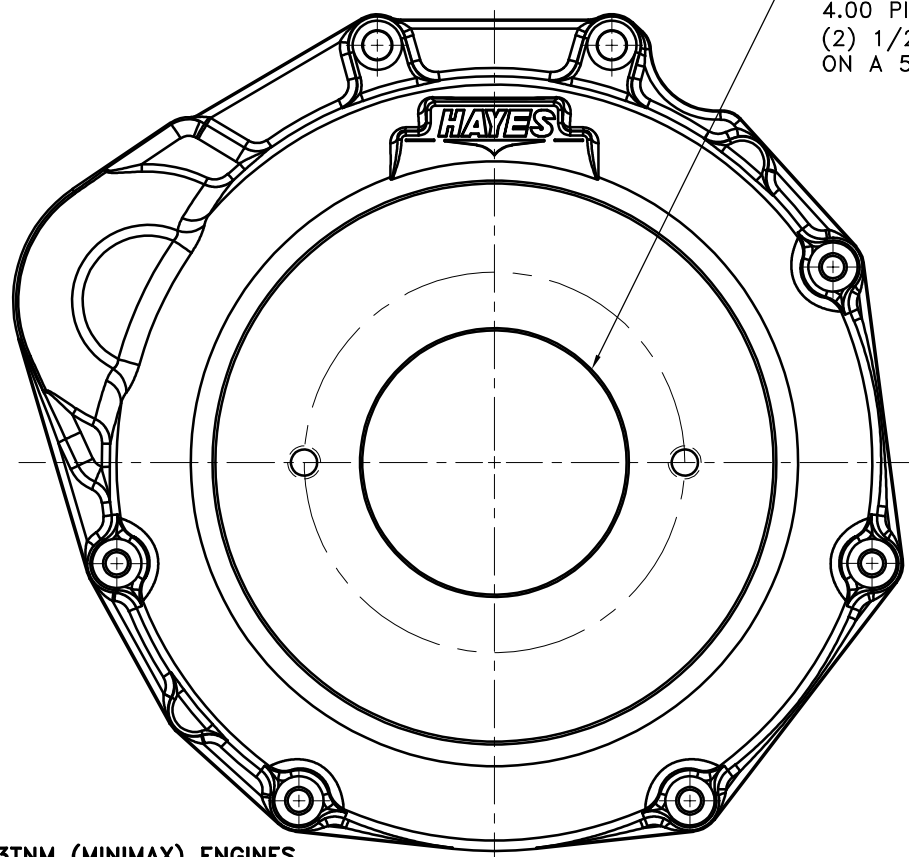
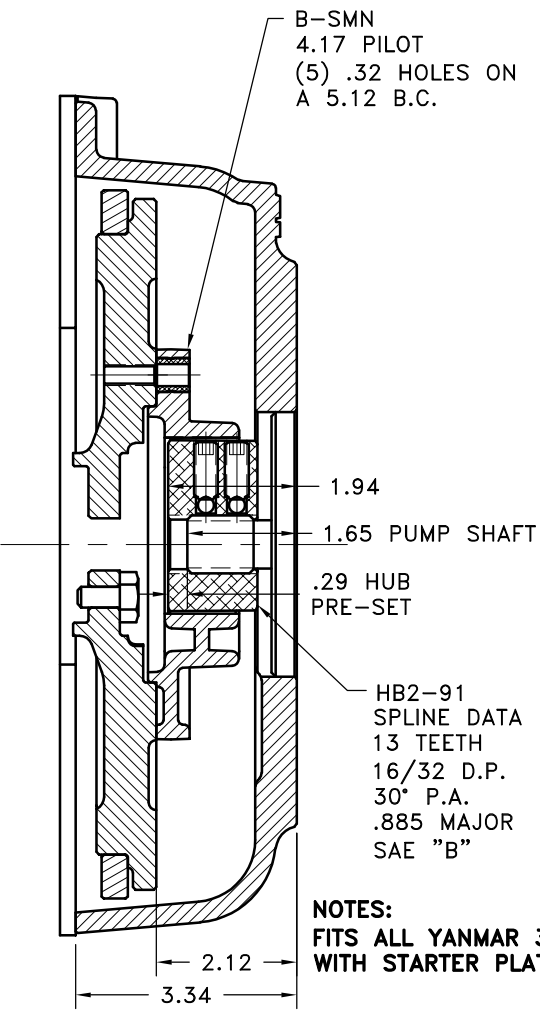

**IMPORTANT INSTALLATION NOTE!!!!**  
**IMPROPER INSTALLATION OF HUB COULD CAUSE**  
**PREMATURE WEAR AND OR FAILURE.**

IF YOU HAVE QUESTIONS CONCERNING LOCATION  
 OF METAL HUB ON PUMP SHAFT PLEASE CONTACT  
 DISTRIBUTOR OR FACTORY FOR FURTHER  
 INFORMATION

**BOTH HUB SET SCREWS MUST BE PROPERLY**  
**TORQUED TO 25 FT.LBS. USING TORQUE WRENCH.**  
**PLEASE CONTACT DISTRIBUTOR OR FACTORY FOR**  
**ANY FURTHER QUESTIONS.**

**NOTES:**  
 FITS ALL YANMAR 3TNM (MINIMAX) ENGINES  
 WITH STARTER PLATE BACK END.

**NOTE: THIS STEP IS IMPORTANT TO**  
**ENSURE FULL SPLINE ENGAGEMENT.**

- 1) PRESET HUB ON SHAFT AS SHOWN.
- 2) IF YOUR PUMP SHAFT VARIES FROM THE DRAWN SHAFT LENGTH, CONTACT FACTORY FOR RECOMMENDATIONS.
- 3) **TORQUE BOTH SET SCREWS TO 25 FT.LBS. USING TORQUE WRENCH.**
- 4) SHAFT SHOULD HAVE FULL SPLINE ENGAGEMENT INTO HUB, IF NOT CONTACT FACTORY FOR RECOMMENDATIONS (231) 879-3372.

THIS DRAWING IS THE PROPERTY OF HAYES MFG. INC. AND IS LOANED SUBJECT TO THE CONDITION THAT IT SHALL NOT BE REPRODUCED, COPIED, LOANED OR OTHERWISE DISPOSED OF, DIRECTLY OR INDIRECTLY. IT SHALL BE USED AS A MEANS OF REFERENCE TO WORK FURNISHED BY THIS COMPANY ONLY AND IS NOT TO BE SUBMITTED TO OUTSIDE PARTIES FOR EXAMINATION WITHOUT OUR CONSENT.

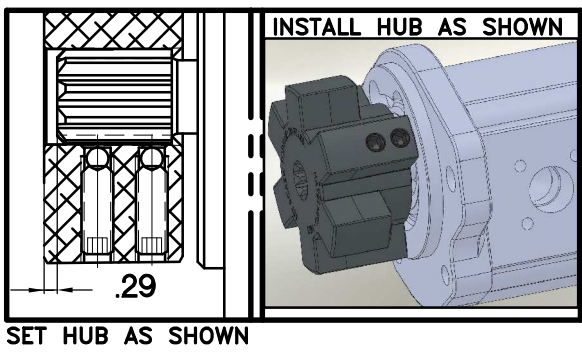

UP TO 50 HP

QTY.	DESCRIPTION	PART NUMBER	DET.
1	BOLT KIT	946002	5
2	5/16 X 1/2 SPRING DOWEL	SD200X5/16X1/2	4
1	HOUSING	946000-03	3
1	HEX~FLX HUB	HB2-91	2
1	HEX~FLX FLYWHEEL PLATE	B-SMN	1

SYMBOLS	DET.	PART NUMBER	DESCRIPTION	QTY.
/ FLATNESS - STRAIGHTNESS < ANGLARITY ⊥ PERPENDICULARITY // PARALLELISM ⊙ CONCENTRICITY ⊕ TRUE POSITION ○ ROUNDNESS ⊖ CIRCULAR RUN OUT ⊖ TOTAL RUN OUT ⊖ CYLINDRICITY ✓ FINISH	DO NOT SCALE DRAWING TOLERANCES UNLESS OTHERWISE SPECIFIED 125 MAXIMUM ANGLE ±1/2° FRACTION ±1/32 DECIMAL .00 ±.01 .000 ±.005 .0000 ±.0005		<b>HAYES</b> MANUFACTURING INC. ® TITLE YANMAR 3TNM (MINIMAX) COUPLING ASS'Y WITH HOUSING MATERIAL	
CLASS YANMAR DESCRIPTION YANMAR,B2	MAKE: <input checked="" type="checkbox"/> BUY: <input type="checkbox"/>	DRAWN BY SIETING CHECKED BY RJH	DATE 08-27-08 SCALE	DRAWING NO. 049-0-HB2-91-B2 SHEET OF REV.