

| REV | DATE | CHANGE DESCRIPTION | MOD.BY | CK1 | CK2 |
|-----|------------|------------------------------|--------|-----|-----|
| B | 05/25/2010 | CHANGED 20.125 DIM TO 20.124 | PB | JM | RJH |

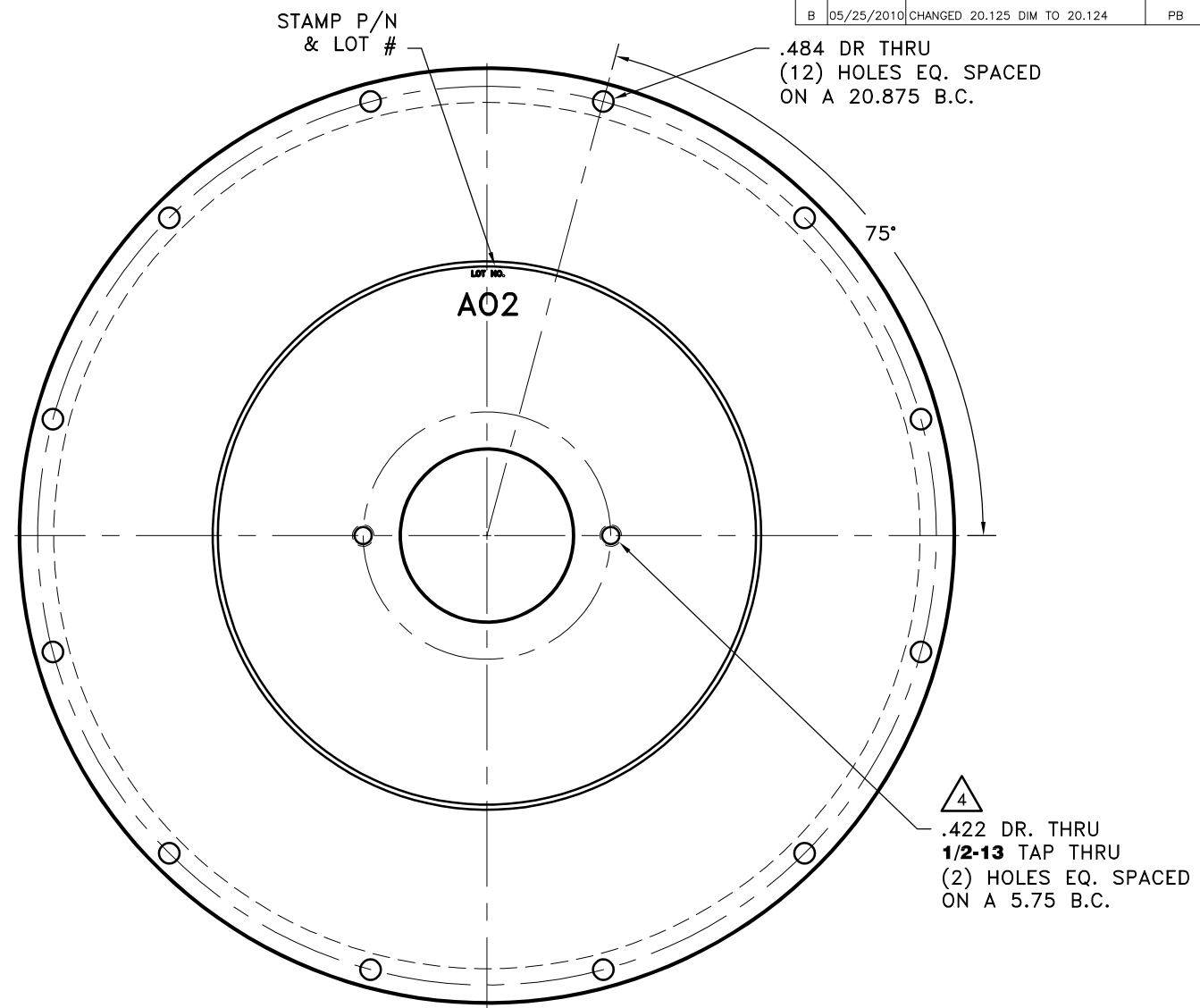
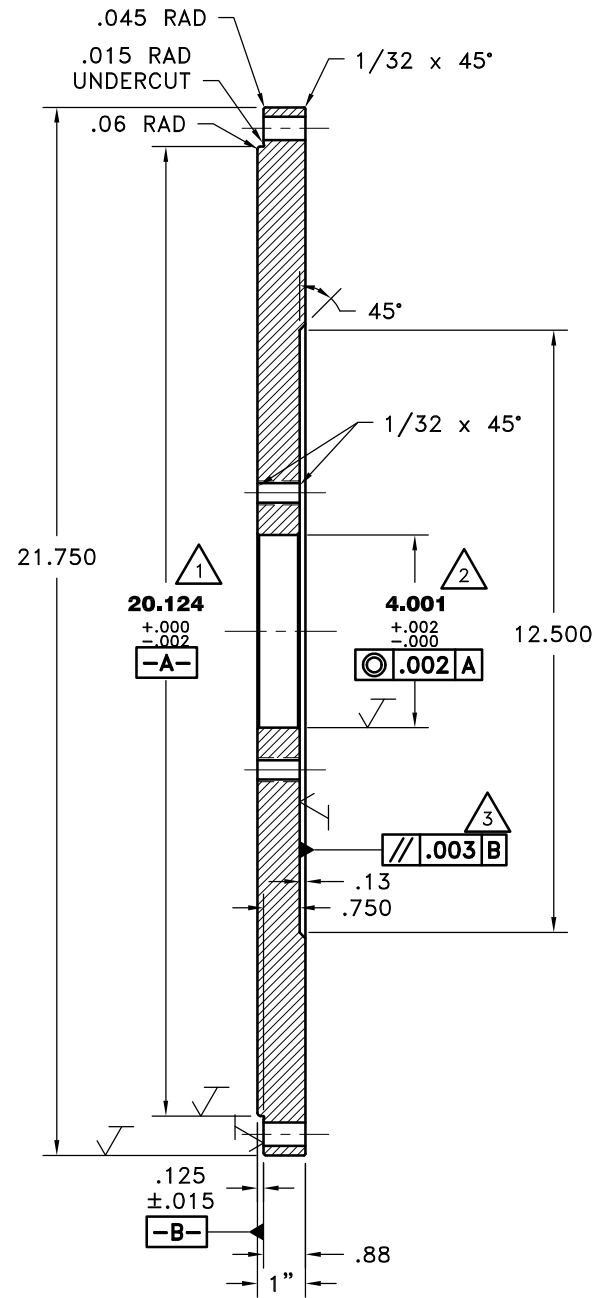

THIS DRAWING IS THE PROPERTY OF HAYES MFG. INC. AND IS LOANED SUBJECT TO THE CONDITION THAT IT SHALL NOT BE REPRODUCED, COPIED, LOANED OR OTHERWISE DISPOSED OF, DIRECTLY OR INDIRECTLY. IT SHALL BE USED AS A MEANS OF REFERENCE TO WORK FURNISHED BY THIS COMPANY ONLY AND IS NOT TO BE SUBMITTED TO OUTSIDE PARTIES FOR EXAMINATION WITHOUT OUR CONSENT.

= CRITICAL FEATURE

| SYMBOLS | | DET. | PART NUMBER | DESCRIPTION | QTY. |
|---|--|---|---------------------|--------------------|---------------------------|
| <ul style="list-style-type: none"> — FLATNESS — STRAIGHTNESS — ANGULARITY — PERPENDICULARITY — PARALLELISM — CONCENTRICITY — TRUE POSITION — ROUNDNESS — CIRCULAR RUN OUT — TOTAL RUN OUT — CYLINDRICITY — FINISH | | DO NOT SCALE DRAWING | | | |
| <ul style="list-style-type: none"> TOLERANCES UNLESS OTHERWISE SPECIFIED 125 MAXIMUM ANGLE ±1/2° FRACTION ±1/32 DECIMAL .00 ±.01 .000 ±.005 .0000 ±.0005 | | | | | |
| CLASS PMP1 | | MAKE: <input checked="" type="checkbox"/> BUY: <input type="checkbox"/> | DRAWN BY SIETING | DATE 11-01-2013 | DRAWING NO. 123008-A02 |
| DESCRIPTION SAE1,B2,1,PMP | | | CHECKED BY RJH | SCALE | SHEET OF REV. |
| TITLE PUMP MOUNT PLATE | | | | | |
| MATERIAL 22.00 OD x 3.75 ID x 1" THICK A36 PLATE | | | | | |