

REV	DATE	CHANGE DESCRIPTION	MOD. BY	CK1	CK2
B	07/07/2010	CHANGED 17.625 DIM TO 17.624	PB	RJH	JM

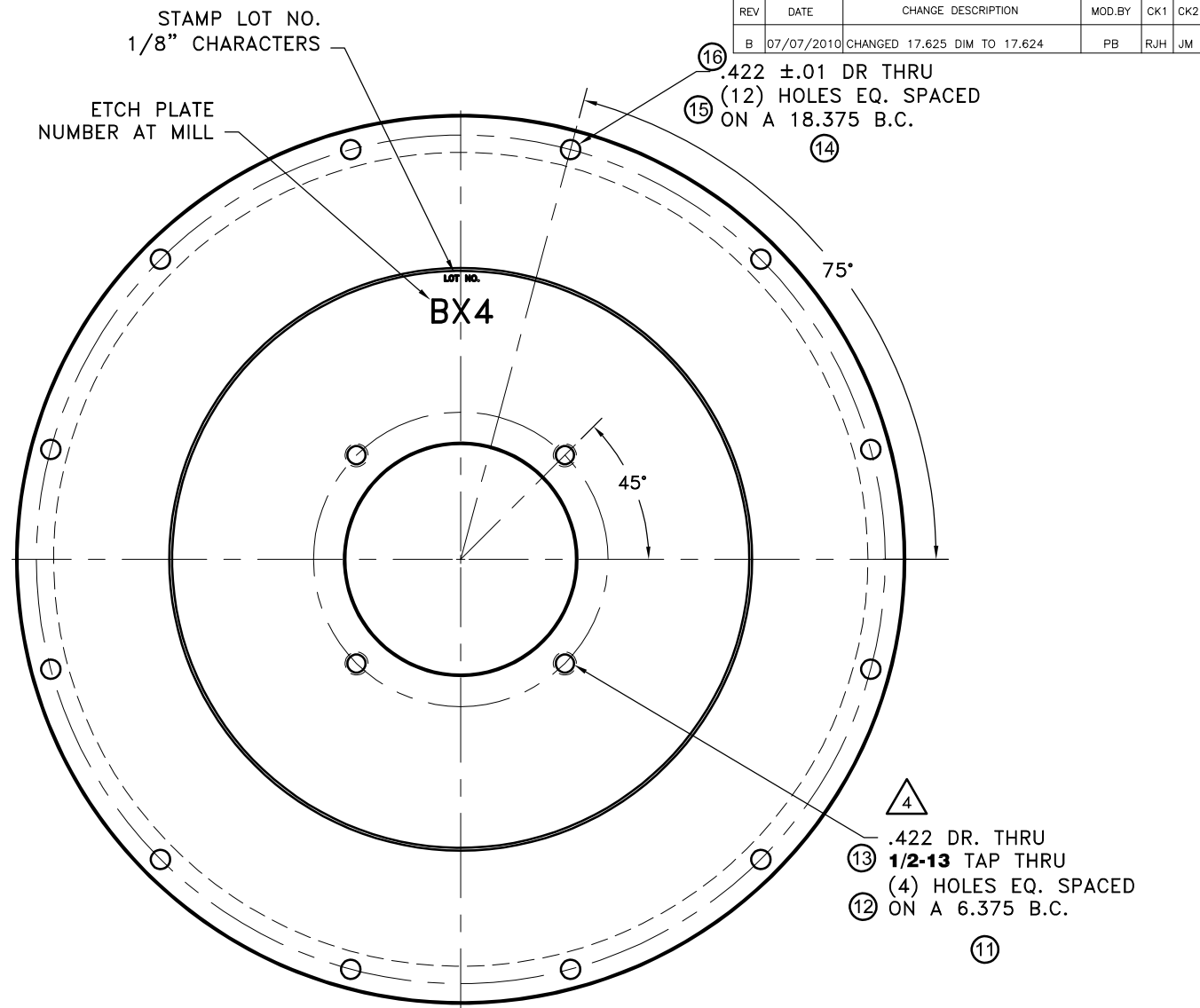
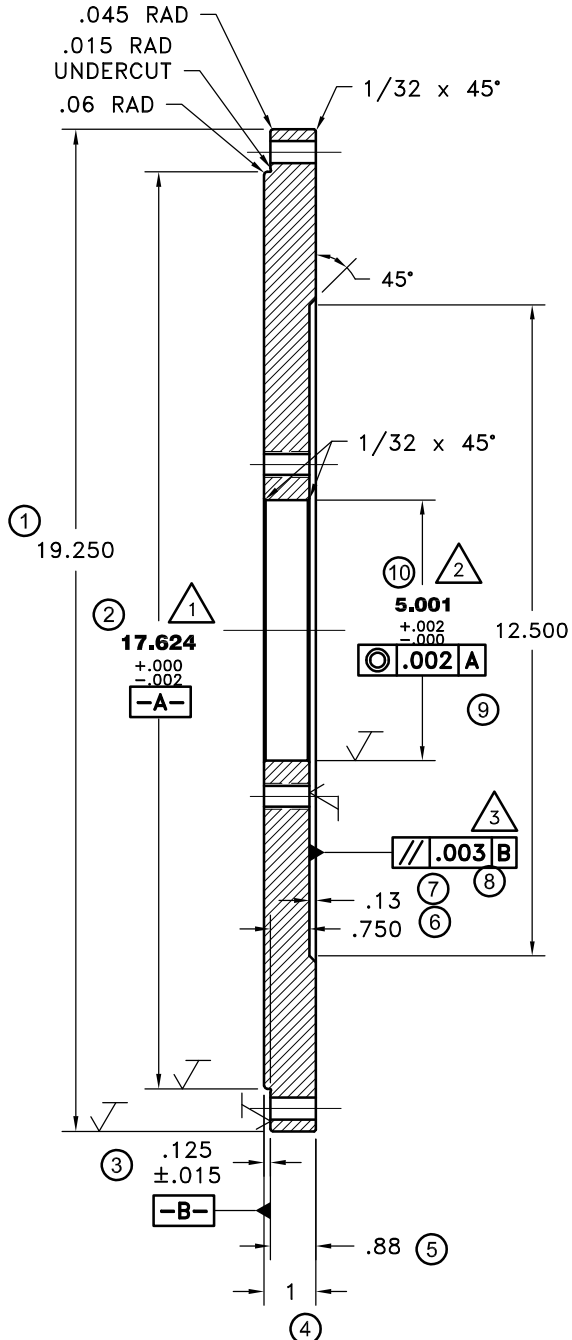

THIS DRAWING IS THE PROPERTY OF HAYES MFG. INC. AND IS LOANED SUBJECT TO THE CONDITION THAT IT SHALL NOT BE REPRODUCED, COPIED, LOANED OR OTHERWISE DISPOSED OF, DIRECTLY OR INDIRECTLY. IT SHALL BE USED AS A MEANS OF REFERENCE TO WORK FURNISHED BY THIS COMPANY ONLY AND IS NOT TO BE SUBMITTED TO OUTSIDE PARTIES FOR EXAMINATION WITHOUT OUR CONSENT.

= CRITICAL FEATURE

SYMBOLS		DET.	PART NUMBER	DESCRIPTION	QTY.
	FLATNESS	DO NOT SCALE			
	STRAIGHTNESS	DRAWING			
	ANGULARITY	TOLERANCES UNLESS OTHERWISE SPECIFIED			
	PERPENDICULARITY	125 MAXIMUM			
	PARALLELISM	ANGLE ±1/2°			
	CONCENTRICITY	FRACTION ±1/32			
	TRUE POSITION	DECIMAL			
	ROUNDNESS	.00 ±.01			
	CIRCULAR RUN OUT	.000 ±.005			
	TOTAL RUN OUT	.0000 ±.0005			
	CYLINDRICITY				
	FINISH				
CLASS		MAKE: <input checked="" type="checkbox"/> BUY: <input type="checkbox"/>	DRAWN BY	DATE	DRAWING NO.
DESCRIPTION			SIETING	03-01-2010	123008-BX4
SAE2,C4,1,PMP			CHECKED BY	SCALE	SHEET OF REV.
			RJH		



PUMP MOUNT PLATE

123008-BXR

DRAWN BY

DATE

DRAWING NO.

123008-BX4

CHECKED BY

RJH

SCALE

SHEET OF REV.