

REV	DATE	CHANGE DESCRIPTION	MOD. BY	CK1	CK2
A1	05/10/2010	MADE NEW PRINTS	ZS	HM	RJH

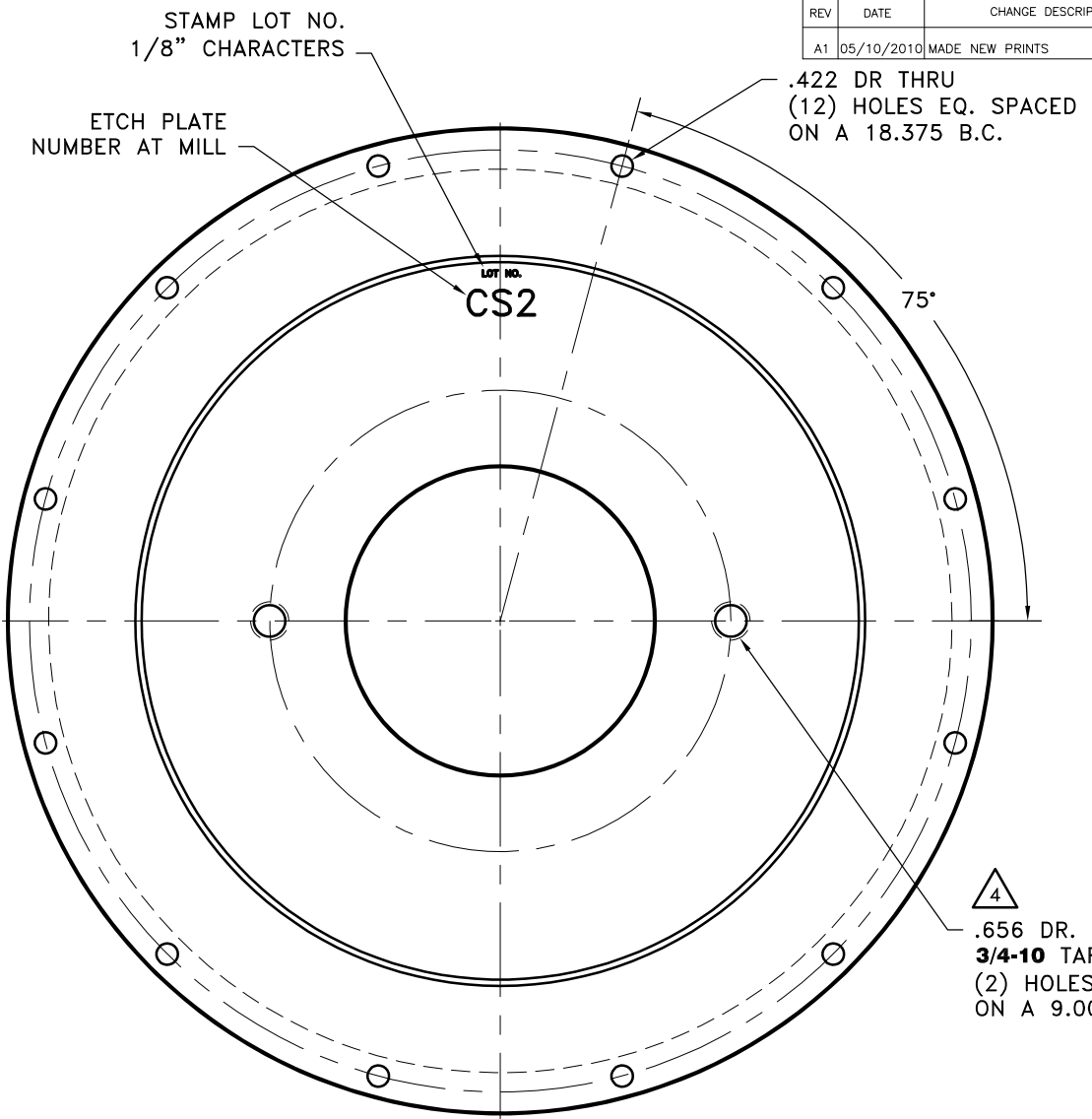
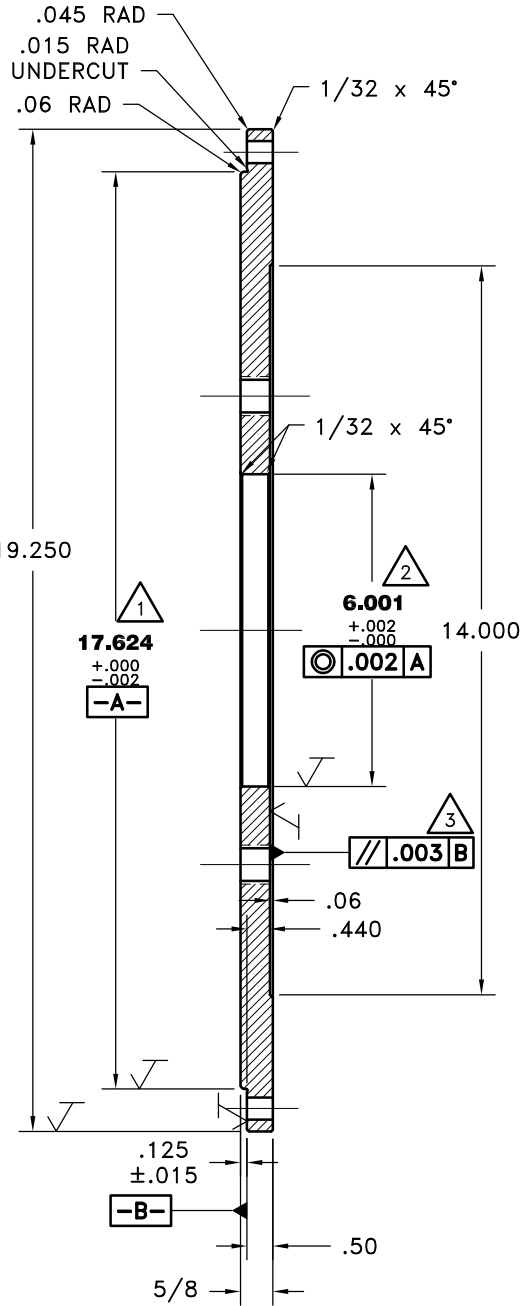

THIS DRAWING IS THE PROPERTY OF HAYES MFG. INC. AND IS LOANED SUBJECT TO THE CONDITION THAT IT SHALL NOT BE REPRODUCED, COPIED, LOANED OR OTHERWISE DISPOSED OF, DIRECTLY OR INDIRECTLY. IT SHALL BE USED AS A MEANS OF REFERENCE TO WORK FURNISHED BY THIS COMPANY ONLY AND IS NOT TO BE SUBMITTED TO OUTSIDE PARTIES FOR EXAMINATION WITHOUT OUR CONSENT.

= CRITICAL FEATURE

SYMBOLS		DET.	PART NUMBER	DESCRIPTION	QTY.
	FLATNESS	DO NOT SCALE		HAYES MANUFACTURING INC. ®	
	STRAIGHTNESS	DRAWING			TITLE
	ANGULARITY	TOLERANCES UNLESS OTHERWISE SPECIFIED		MATERIAL	123008-CSR
	PERPENDICULARITY	125 MAXIMUM		DRAWN BY	DATE
	PARALLELISM	ANGLE ±1/2°		SIETING	05-10-2010
	CONCENTRICITY	FRACTION ±1/32		CHECKED BY	SCALE
	TRUE POSITION	DECIMAL		RJH	
	ROUNDNESS	.00 ±.01		DESCRIPTION	SAE2,D2,.625,PMP
	CIRCULAR RUN OUT	.000 ±.005			
	TOTAL RUN OUT	.0000 ±.0005			
	CYLINDRICITY				
	FINISH				