

REV	DATE	CHANGE DESCRIPTION	MOD. BY	CK1	CK2
A1	05/10/2010	MADE NEW PRINTS	ZS	HM	RJH

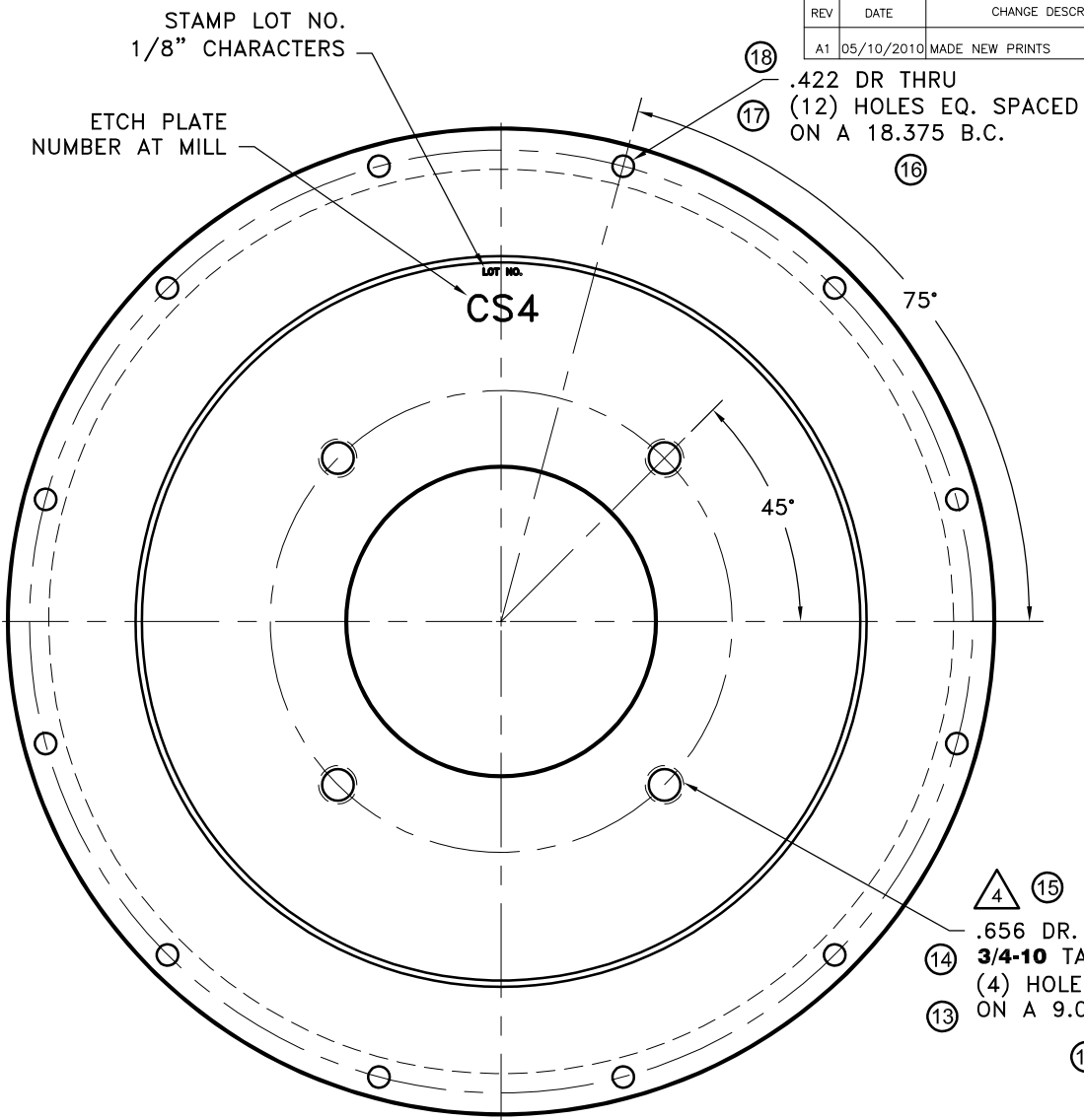
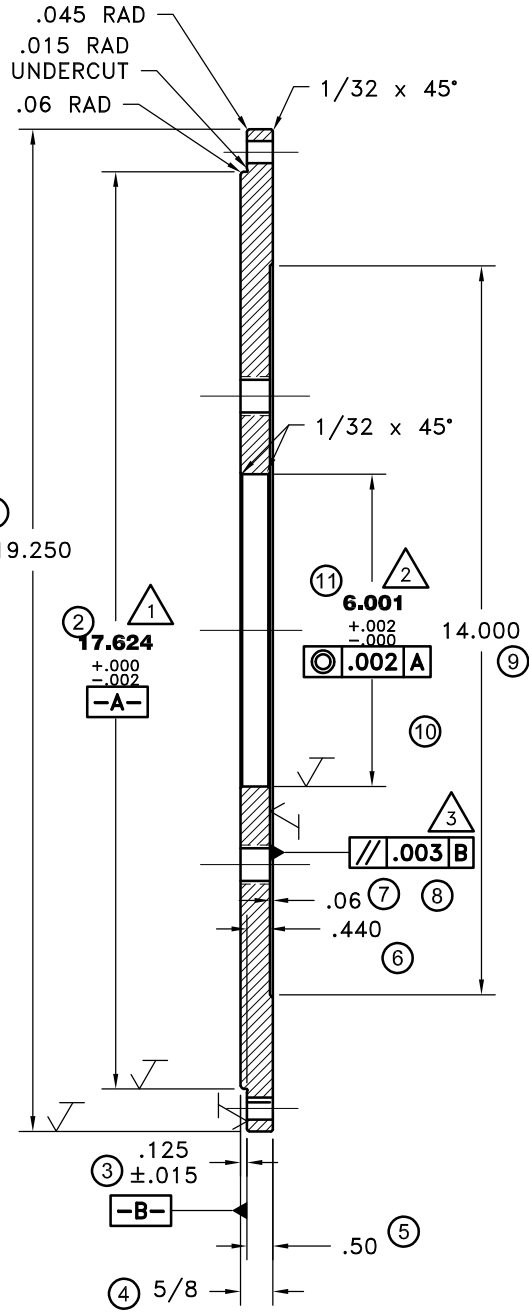

⑬ .422 DR THRU
(12) HOLES EQ. SPACED
ON A 18.375 B.C.

⑭ .656 DR. THRU
3/4-10 TAP THRU
(4) HOLES EQ. SPACED
ON A 9.000 B.C.

THIS DRAWING IS THE PROPERTY OF HAYES MFG. INC. AND IS LOANED SUBJECT TO THE CONDITION THAT IT SHALL NOT BE REPRODUCED, COPIED, LOANED OR OTHERWISE DISPOSED OF, DIRECTLY OR INDIRECTLY. IT SHALL BE USED AS A MEANS OF REFERENCE TO WORK FURNISHED BY THIS COMPANY ONLY AND IS NOT TO BE SUBMITTED TO OUTSIDE PARTIES FOR EXAMINATION WITHOUT OUR CONSENT.

= CRITICAL FEATURE

SYMBOLS	DET.	PART NUMBER	DESCRIPTION	QTY.
<ul style="list-style-type: none"> — FLATNESS — STRAIGHTNESS — ANGULARITY ⊥ PERPENDICULARITY ∥ PARALLELISM ⊙ CONCENTRICITY ⊕ TRUE POSITION ○ ROUNDNESS ⊘ CIRCULAR RUN OUT ⊖ TOTAL RUN OUT ⊘ CYLINDRICITY ✓ FINISH 	DO NOT SCALE DRAWING TOLERANCES UNLESS OTHERWISE SPECIFIED 125 MAXIMUM ANGLE ±1/2° FRACTION ±1/32 DECIMAL .00 ±.01 .000 ±.005 .0000 ±.0005	MAKE: <input checked="" type="checkbox"/> BUY: <input type="checkbox"/>	<div style="text-align: center;">HAYES</div> MANUFACTURING INC. ® PUMP MOUNT PLATE MATERIAL 123008-CSR	TITLE 123008-CS4 SHEET OF REV.
CLASS PMP2 DESCRIPTION SAE2,D4,.625,PMP	DRAWN BY SIETING CHECKED BY RJH	DATE 05-10-2010 SCALE	DRAWN NO. 123008-CS4 SHEET OF REV.	