

| REV | DATE | CHANGE DESCRIPTION | MOD.BY | CK1 | CK2 |
|-----|------------|---------------------------------|--------|-----|-----|
| B | 05/10/2010 | CHANGED HOUSING PILOT TO 16.124 | PB | HM | JM |

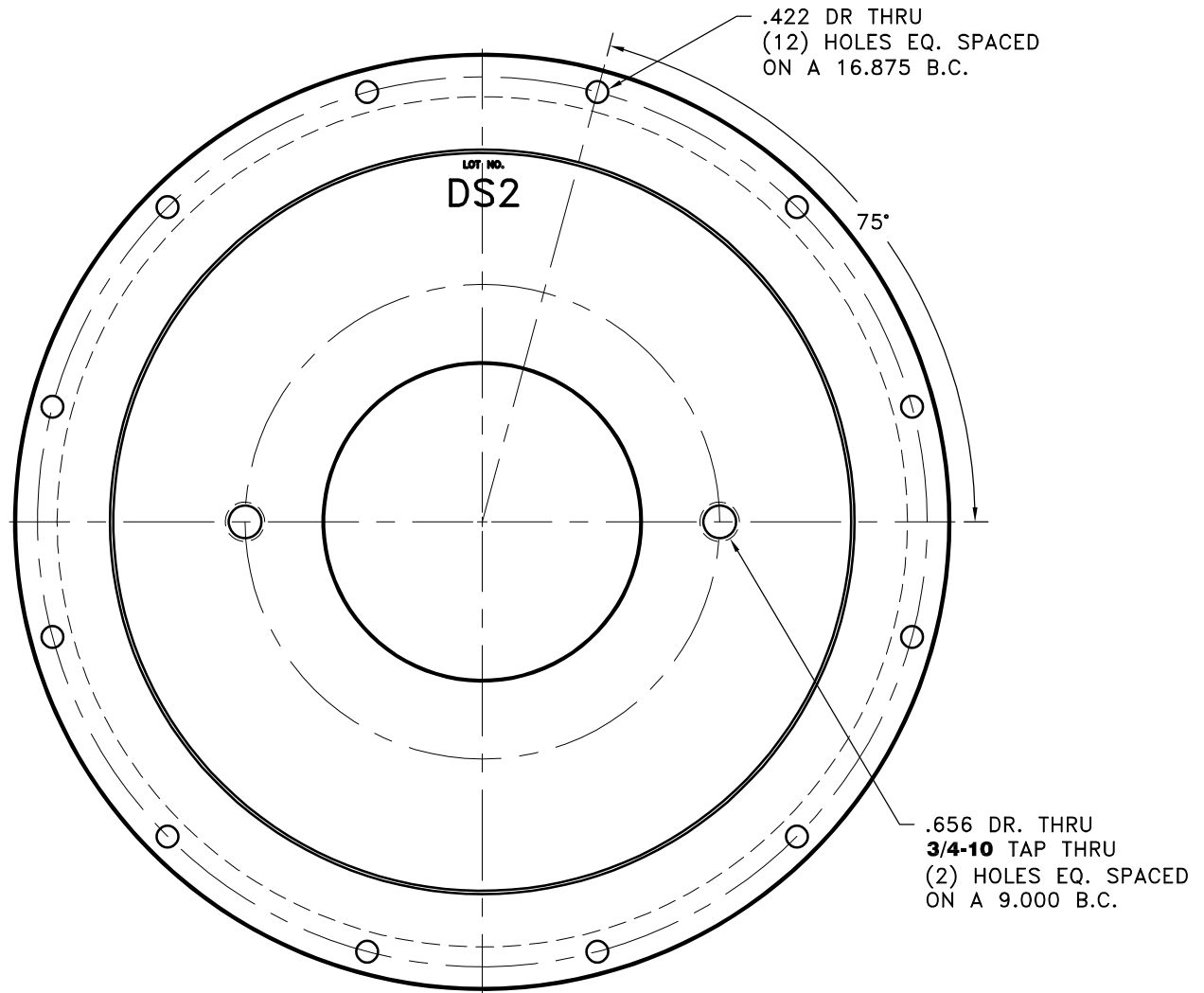
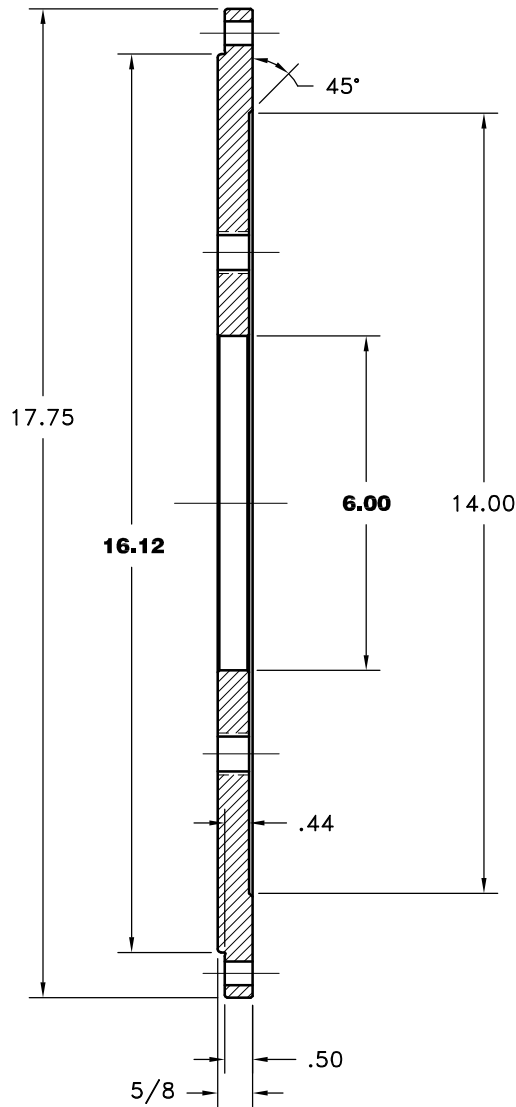

THIS DRAWING IS THE PROPERTY OF HAYES MFG. INC. AND IS LOANED SUBJECT TO THE CONDITION THAT IT SHALL NOT BE REPRODUCED, COPIED, LOANED OR OTHERWISE DISPOSED OF, DIRECTLY OR INDIRECTLY. IT SHALL BE USED AS A MEANS OF REFERENCE TO WORK FURNISHED BY THIS COMPANY ONLY AND IS NOT TO BE SUBMITTED TO OUTSIDE PARTIES FOR EXAMINATION WITHOUT OUR CONSENT.

| SYMBOLS | | DET. | PART NUMBER | DESCRIPTION | QTY. |
|------------------|---|---------------------------------------|-------------|--------------------------------------|------------|
| | FLATNESS | DO NOT SCALE | | HAYES MANUFACTURING INC. ® | |
| | STRAIGHTNESS | DRAWING | | | TITLE |
| | ANGULARITY | TOLERANCES UNLESS OTHERWISE SPECIFIED | | | 123008-DSR |
| | PERPENDICULARITY | 125 MAXIMUM | | MATERIAL | 123008-DSR |
| | PARALLELISM | ANGLE ±1/2° | | | |
| | CONCENTRICITY | FRACTION ±1/32 | | | |
| | TRUE POSITION | DECIMAL | | | |
| | ROUNDNESS | .00 ±.01 | | | |
| | CIRCULAR RUN OUT | .000 ±.005 | | | |
| | TOTAL RUN OUT | .0000 ±.0005 | | | |
| | CYLINDRICITY | | | | |
| | FINISH | | | | |
| CLASS | MAKE: <input checked="" type="checkbox"/> BUY: <input type="checkbox"/> | DRAWN BY | DATE | DRAWING NO. | |
| DESCRIPTION | | SIETING | 03-08-2010 | 123008-DS2 | |
| SAE3,D2,.625,PMP | | CHECKED BY | SCALE | SHEET OF REV. | |
| | | RJH | | | |