

REV	DATE	CHANGE DESCRIPTION	MOD.BY	CK1	CK2

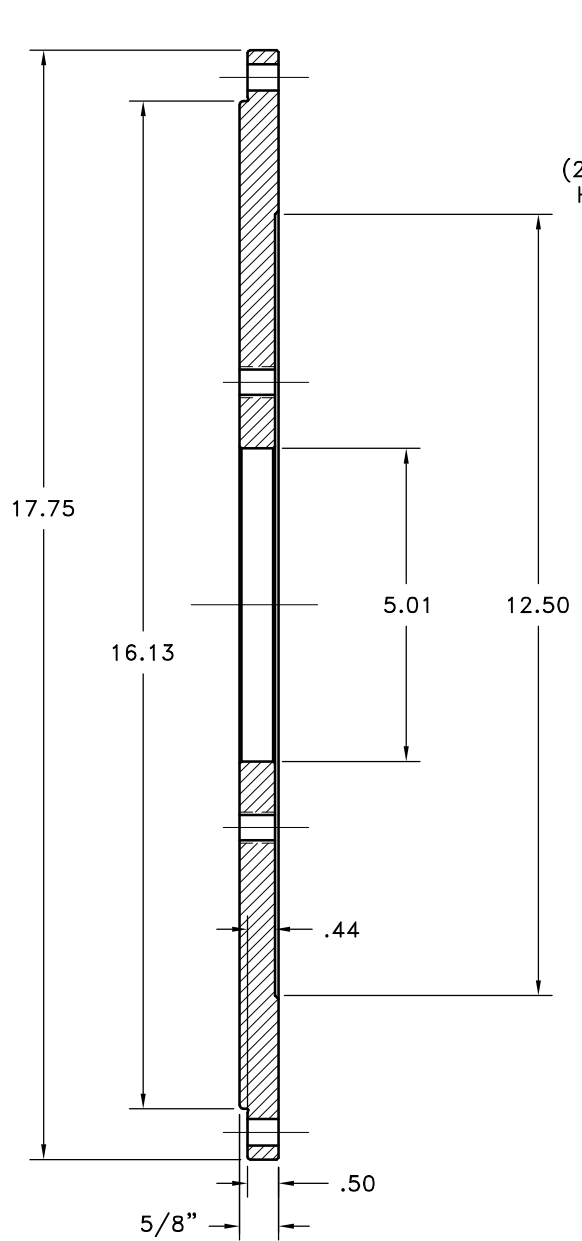

(12) 27/64 HOLES
EQ. SPACED
ON A 16 7/8 B.C.

(2) 5/8-11 TAPPED
HOLES EQ. SPACED
ON A 7 1/8 B.C.

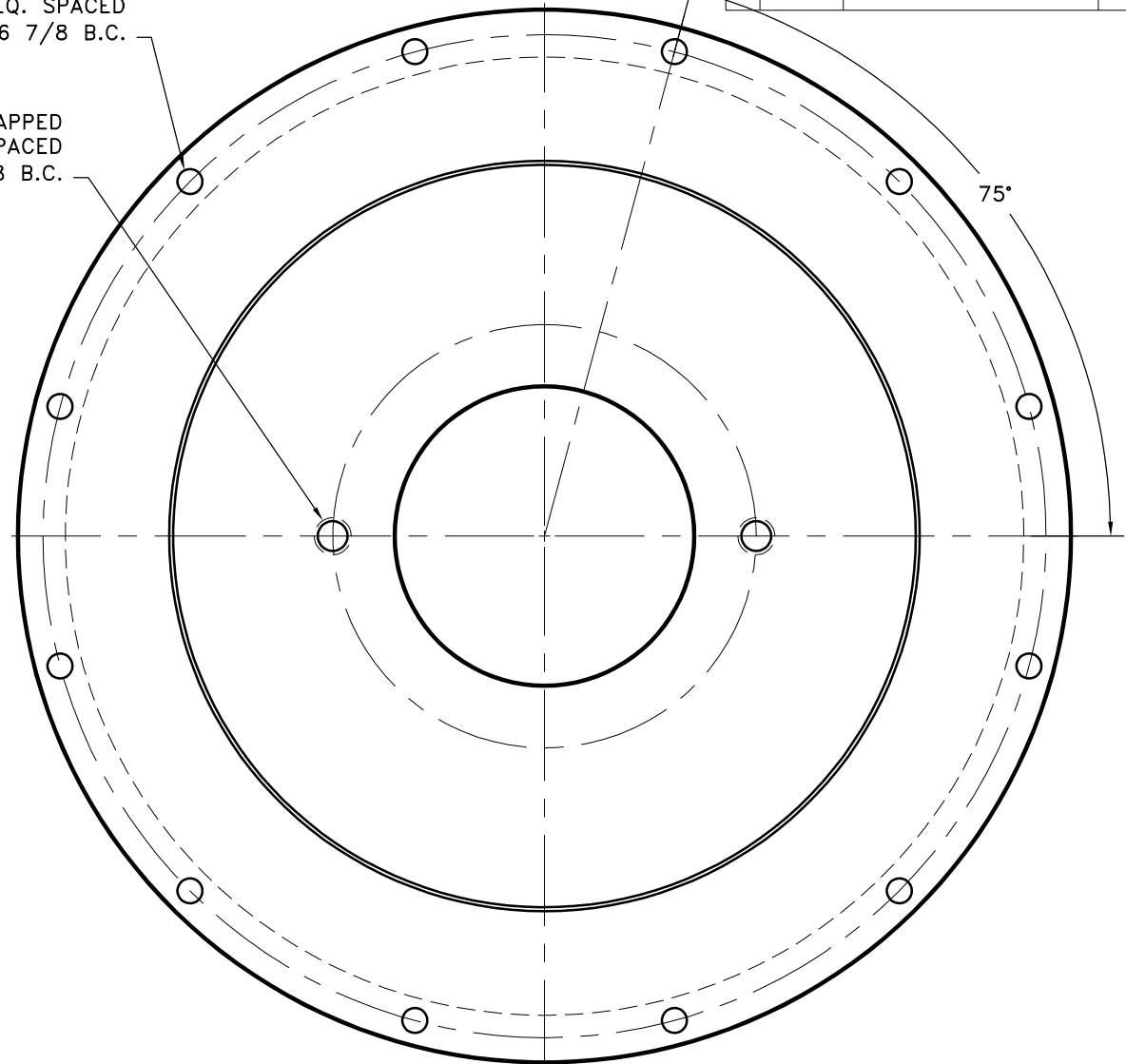

THIS DRAWING IS THE PROPERTY OF HAYES MFG. INC. AND IS LOANED SUBJECT TO THE CONDITION THAT IT SHALL NOT BE REPRODUCED, COPIED, LOANED OR OTHERWISE DISPOSED OF, DIRECTLY OR INDIRECTLY. IT SHALL BE USED AS A MEANS OF REFERENCE TO WORK FURNISHED BY THIS COMPANY ONLY AND IS NOT TO BE SUBMITTED TO OUTSIDE PARTIES FOR EXAMINATION WITHOUT OUR CONSENT.

SYMBOLS	DET.	PART NUMBER	DESCRIPTION	QTY.
<ul style="list-style-type: none"> — FLATNESS — STRAIGHTNESS — ANGULARITY — PERPENDICULARITY — PARALLELISM — CONCENTRICITY — TRUE POSITION — ROUNDNESS — CIRCULAR RUN OUT — TOTAL RUN OUT — CYLINDRICITY — FINISH 	DO NOT SCALE DRAWING TOLERANCES UNLESS OTHERWISE SPECIFIED 125 MAXIMUM ANGLE ±1/2° FRACTION ±1/32 DECIMAL .00 ±.01 .000 ±.005 .0000 ±.0005		 SAE 3, C 2 BOLT P.M.P.	
CLASS	MAKE: <input type="checkbox"/> BUY: <input type="checkbox"/>	DRAWN BY SIETING	DATE 04-26-07	DRAWING NO. 123008-DX2
DESCRIPTION		CHECKED BY RJH	SCALE	SHEET OF REV.