

REV	DATE	CHANGE DESCRIPTION	MOD.BY	CK1	CK2

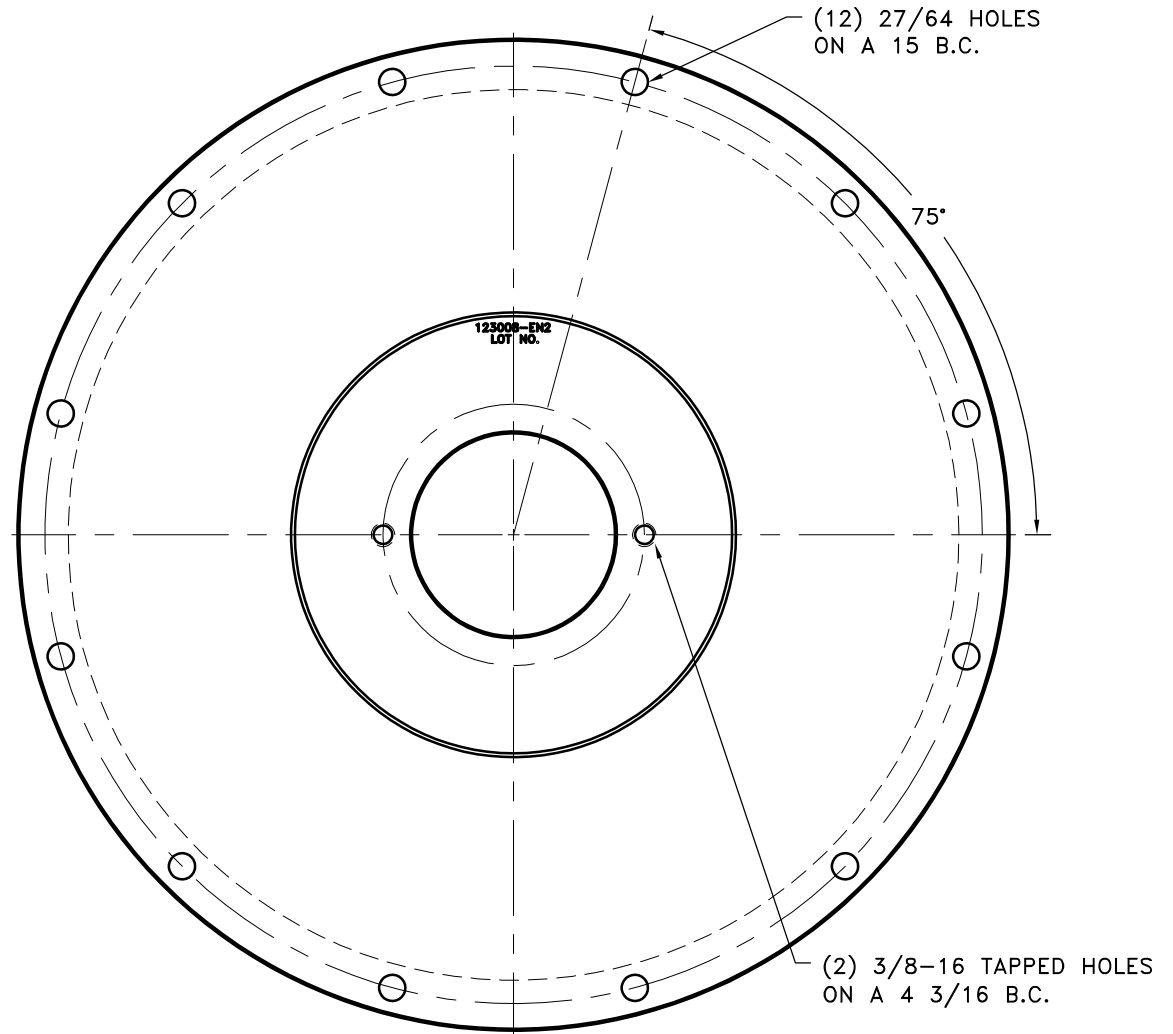
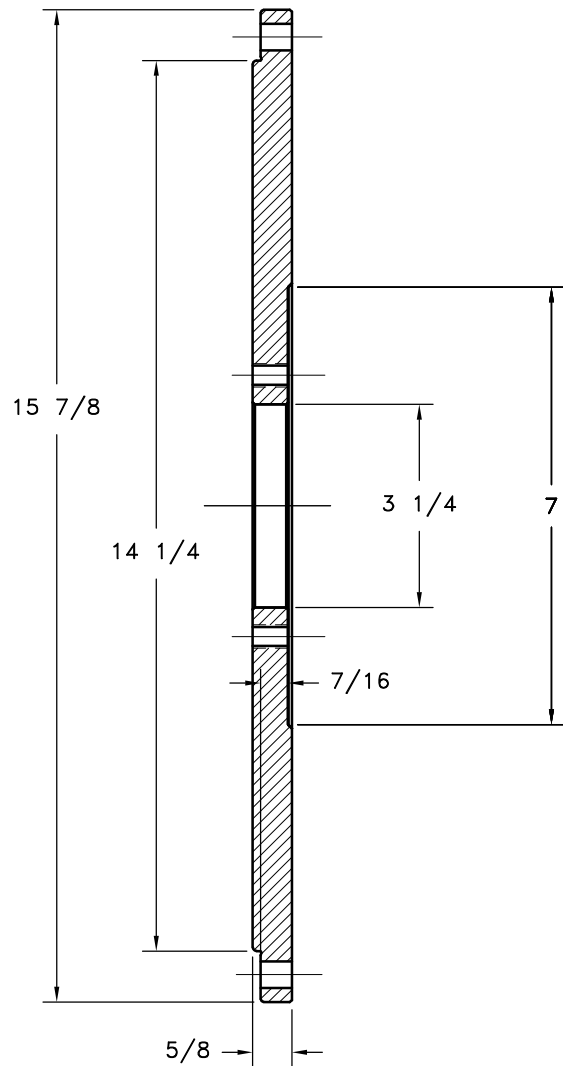

THIS DRAWING IS THE PROPERTY OF HAYES MFG. INC. AND IS LOANED SUBJECT TO THE CONDITION THAT IT SHALL NOT BE REPRODUCED, COPIED, LOANED OR OTHERWISE DISPOSED OF, DIRECTLY OR INDIRECTLY. IT SHALL BE USED AS A MEANS OF REFERENCE TO WORK FURNISHED BY THIS COMPANY ONLY AND IS NOT TO BE SUBMITTED TO OUTSIDE PARTIES FOR EXAMINATION WITHOUT OUR CONSENT.

SYMBOLS	DET.	PART NUMBER	DESCRIPTION	QTY.
<ul style="list-style-type: none"> ▭ FLATNESS — STRAIGHTNESS ∠ ANGULARITY ⊥ PERPENDICULARITY ∥ PARALLELISM ⊙ CONCENTRICITY ⊕ TRUE POSITION ○ ROUNDNESS ⊖ CIRCULAR RUN OUT ⊖ TOTAL RUN OUT ⊖ CYLINDRICITY ✓ FINISH 	DO NOT SCALE DRAWING			
	TOLERANCES UNLESS OTHERWISE SPECIFIED			TITLE
	125 MAXIMUM ANGLE ±1/2° FRACTION ±1/32 DECIMAL .00 ±.01 .000 ±.005 .0000 ±.0005		MATERIAL	
CLASS	MAKE: <input type="checkbox"/> BUY: <input type="checkbox"/>	DRAWN BY	DATE	DRAWING NO.
DESCRIPTION		SEITING	02-11-2010	123008-EN2
		CHECKED BY	SCALE	SHEET OF REV.