

REV	DATE	CHANGE DESCRIPTION	MOD.BY	CK1	CK2

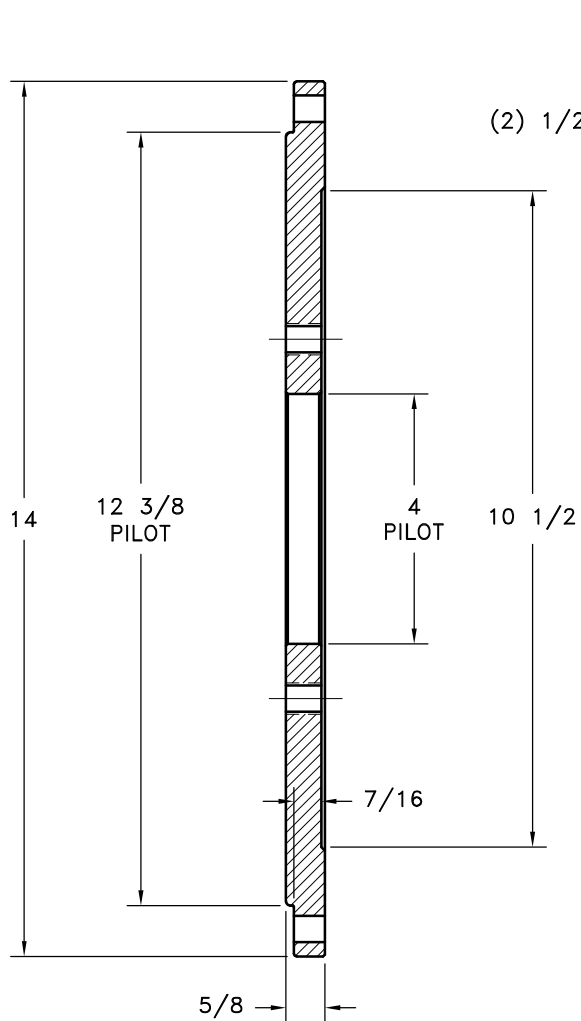

(8) 27/64 HOLES
ON A 13 1/8 B.C.

(2) 1/2-13 TAPPED HOLES
ON A 5 3/4 B.C.

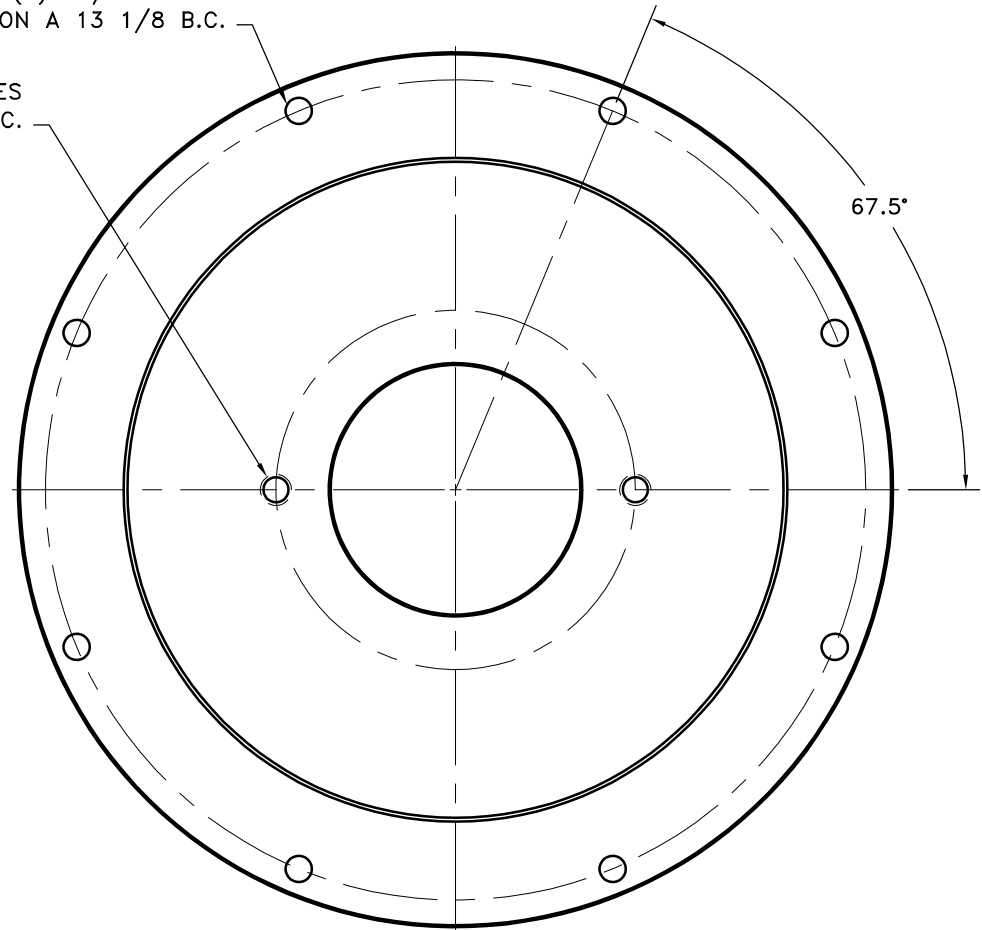

THIS DRAWING IS THE PROPERTY OF HAYES MFG. INC. AND IS LOANED SUBJECT TO THE CONDITION THAT IT SHALL NOT BE REPRODUCED, COPIED, LOANED OR OTHERWISE DISPOSED OF, DIRECTLY OR INDIRECTLY. IT SHALL BE USED AS A MEANS OF REFERENCE TO WORK FURNISHED BY THIS COMPANY ONLY AND IS NOT TO BE SUBMITTED TO OUTSIDE PARTIES FOR EXAMINATION WITHOUT OUR CONSENT.

SYMBOLS		DET.	PART NUMBER	DESCRIPTION	QTY.
▭	FLATNESS	DO NOT SCALE		HAYES MANUFACTURING INC. ®	
—	STRAIGHTNESS	DRAWING			TITLE
∠	ANGULARITY	TOLERANCES UNLESS OTHERWISE SPECIFIED		SAE 5, B 2 BOLT P.M.P.	
⊥	PERPENDICULARITY	125 MAXIMUM		MATERIAL	
∥	PARALLELISM	ANGLE ±1/2°		DRAWN BY	DATE
⊙	CONCENTRICITY	FRACTION ±1/32		SIETING	11-20-06
⊕	TRUE POSITION	DECIMAL		CHECKED BY	SCALE
⊖	ROUNDNESS	.00 ±.01		RJH	
⊘	CIRCULAR RUN OUT	.000 ±.005			
⊘	TOTAL RUN OUT	.0000 ±.0005			
⊘	CYLINDRICITY				
✓	FINISH				
CLASS	PMP5	MAKE: <input checked="" type="checkbox"/> BUY: <input type="checkbox"/>	DRAWN BY	DATE	DRAWING NO.
DESCRIPTION	SAE4,A2,.625,PMP		SIETING	11-20-06	123008-GO2
			CHECKED BY	SCALE	SHEET OF REV.
			RJH		