

REV	DATE	CHANGE DESCRIPTION	MOD.BY	CK1	CK2
F	12/01/1997	CHANGED .3906 TO .406	RH		

PT# 123008-DS2
 S.A.E HOUSING MOUNT 27/64 DRILL THRU
 12 HOLES EQUALLY SPACED ON 16.88 B.C.
 6" PUMP PILOT S.A.E. "D" PUMP MOUNT.
 (2) 3/4-10 TAPPED HOLES EQUALLY
 SPACED ON 9" B.C.

123243-37
 13.874 O.D.
 (8) .406 HOLES
 ON 13.125 B.C.

123214-16
 SPLINE DATA
 14 TEETH
 12/24 D.P.
 30° P.A.
 1.263 MAJOR
 SAE "C"

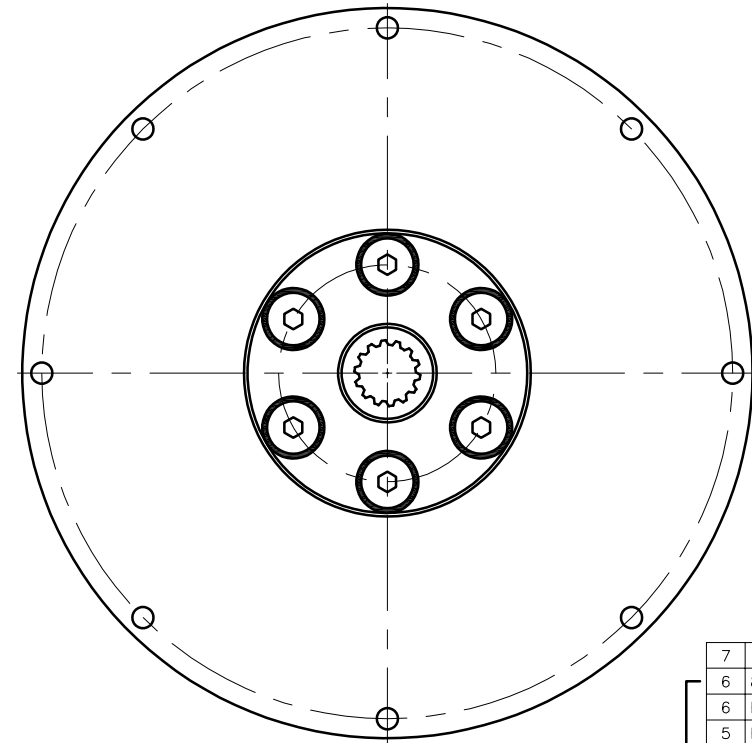
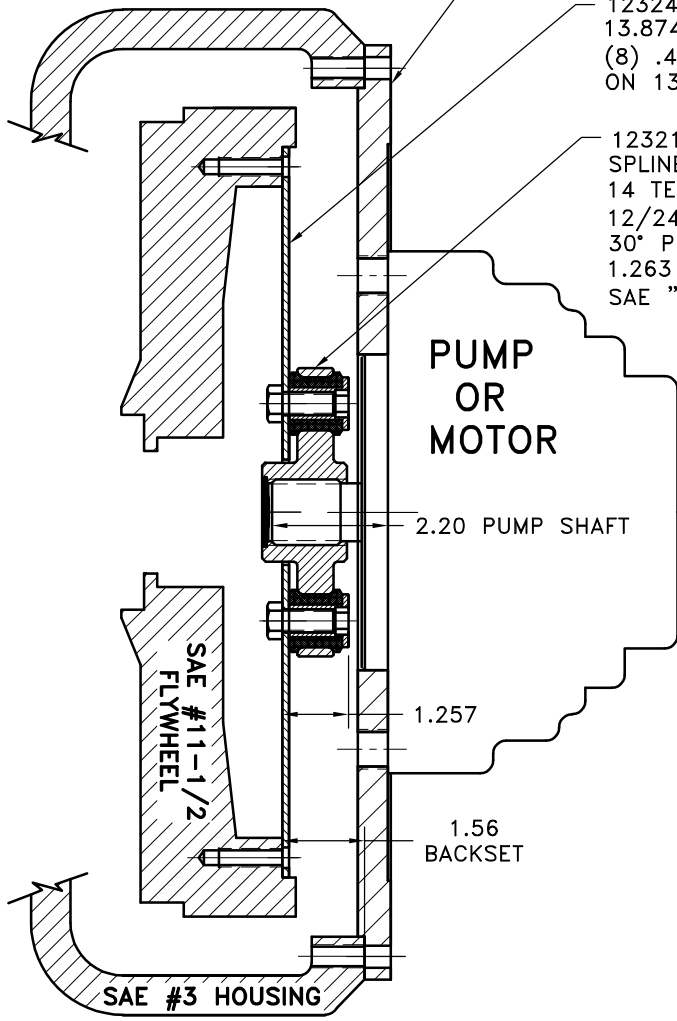

COUPLING ASS'Y #123168

UP TO 110 HP

QTY.	PART NUMBER	DESCRIPTION
1	123008-DS2	PUMP MOUNT PLATE
1	801912	GREASE
1	HP-1312-S-62	HUBBARD PLUG
6	HX200	7/16-20-1" BOLT
6	123727	THREADED BUSHING
6	H62500	NEOPRENE INSERT
1	123214-16	COUPLING HUB
1	123243-37	FLYWHEEL PLATE

SYMBOLS	DET.	PART NUMBER	DESCRIPTION	QTY.
▱ FLATNESS — STRAIGHTNESS ∠ ANGULARITY ⊥ PERPENDICULARITY ∥ PARALLELISM ⊙ CONCENTRICITY ⊕ TRUE POSITION ○ ROUNDNESS Ⓢ CIRCULAR RUN OUT Ⓣ TOTAL RUN OUT Ⓜ CYLINDRICITY ✓ FINISH	DO NOT SCALE DRAWING			
	TOLERANCES UNLESS OTHERWISE SPECIFIED			
	125 MAXIMUM			
	ANGLE ±1/2°			
	FRACTION ±1/32			
	DECIMAL			
	.00 ±.01			
	.000 ±.005			
	.0000 ±.0005			
CLASS	MAKE: <input checked="" type="checkbox"/> BUY: <input type="checkbox"/>	DRAWN BY	DATE	DRAWING NO.
SAE 11.5		SIETING	4-25-89	123167
DESCRIPTION		CHECKED BY	SCALE	SHEET OF REV.
11-1/2,3,14T12/24,D2,110		RJH		123167 OF REV.



TITLE
 FLYWHEEL COUPLING ASS'Y WITH PUMP MT. PLATE

THIS DRAWING IS THE PROPERTY OF HAYES MFG. INC. AND IS LOANED SUBJECT TO THE CONDITION THAT IT SHALL NOT BE REPRODUCED, COPIED, LOANED OR OTHERWISE DISPOSED OF, DIRECTLY OR INDIRECTLY. IT SHALL BE USED AS A MEANS OF REFERENCE TO WORK FURNISHED BY THIS COMPANY ONLY AND IS NOT TO BE SUBMITTED TO OUTSIDE PARTIES FOR EXAMINATION WITHOUT OUR CONSENT.