

REV	DATE	CHANGE DESCRIPTION	MOD. BY	CK1	CK2
D	07/24/2001	CHANGED TO BOLTED	MAYCROFT	HM	MM

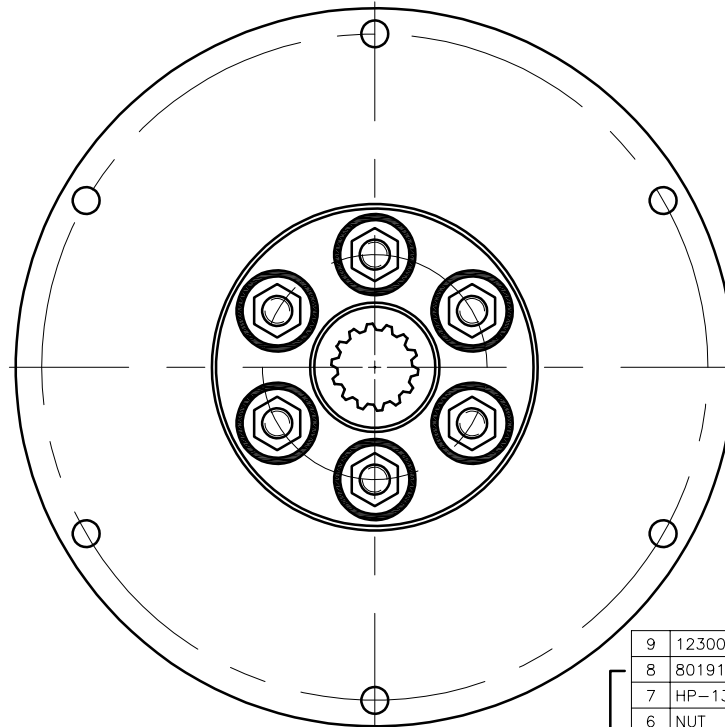
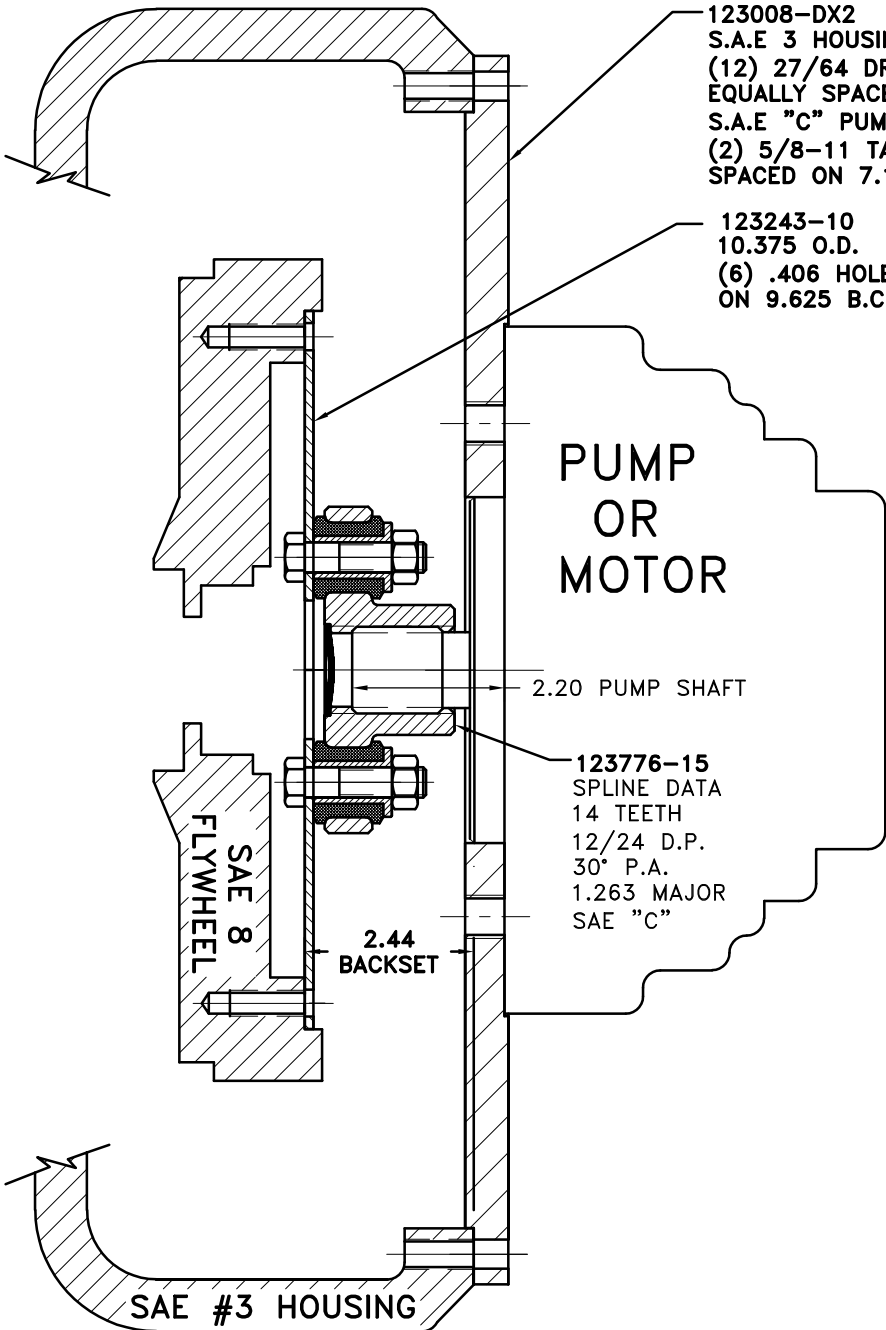

**COUPLING ASS'Y
#123316**

UP TO 65 HP

QTY.	PART NUMBER	DESCRIPTION
1	123008-DX2	PUMP MOUNT PLATE
1	801912	GREASE
1	HP-1312-S-62	HUBBARD PLUG
6	NUT	7/16-20 NUT
6	BOLT	7/16-20x1-3/4 HHB DRILOC
6	123000-00	STEEL BUSHING
6	H62500	NEOPRENE INSERT
1	123776-15	COUPLING HUB
1	123243-10	FLYWHEEL PLATE

SYMBOLS	DET.	PART NUMBER	DESCRIPTION	QTY.
▱ FLATNESS — STRAIGHTNESS ∠ ANGULARITY ⊥ PERPENDICULARITY ∥ PARALLELISM ⊙ CONCENTRICITY ⊕ TRUE POSITION ○ ROUNDNESS Ⓢ CIRCULAR RUN OUT Ⓣ TOTAL RUN OUT Ⓜ CYLINDRICITY Ⓩ FINISH	DO NOT SCALE DRAWING TOLERANCES UNLESS OTHERWISE SPECIFIED 125 MAXIMUM ANGLE ±1/2° FRACTION ±1/32 DECIMAL .00 ±.01 .000 ±.005 .0000 ±.0005			
CLASS SAE 8	MAKE: <input checked="" type="checkbox"/> BUY: <input type="checkbox"/>	DRAWN BY LANNEN	DATE 9-7-89	DRAWING NO. 123315
DESCRIPTION 8,3,14T12/24,C2,65		CHECKED BY SCALE		SHEET OF REV. 123315

THIS DRAWING IS THE PROPERTY OF HAYES MFG. INC. AND IS LOANED SUBJECT TO THE CONDITION THAT IT SHALL NOT BE REPRODUCED, COPIED, LOANED OR OTHERWISE DISPOSED OF, DIRECTLY OR INDIRECTLY. IT SHALL BE USED AS A MEANS OF REFERENCE TO WORK FURNISHED BY THIS COMPANY ONLY AND IS NOT TO BE SUBMITTED TO OUTSIDE PARTIES FOR EXAMINATION WITHOUT OUR CONSENT.