

REV	DATE	CHANGE DESCRIPTION	MOD.BY	CK1	CK2
I	01/15/2013	CHANGED TO THREADED BUSHINGS	ZS	HM	JM

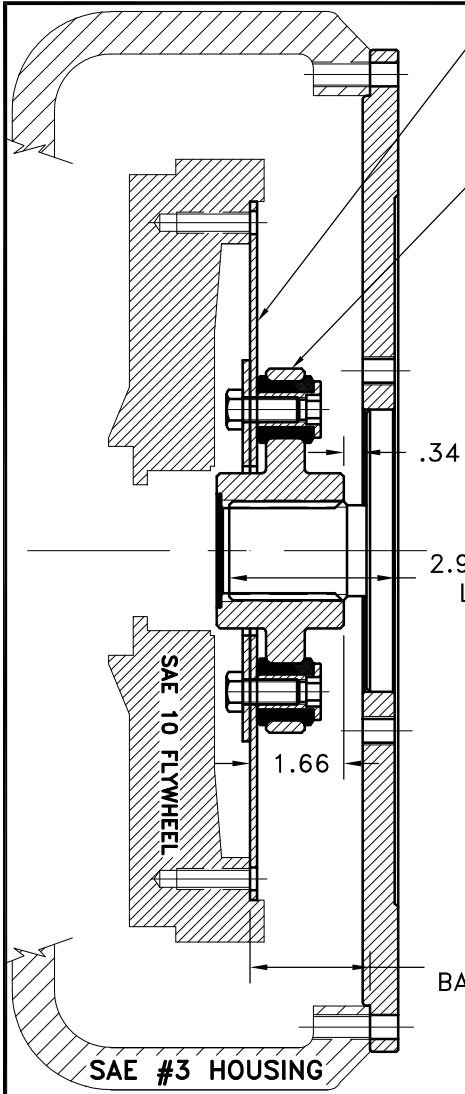

123243-22
12.374 O.D.
(8) .406 HOLES
ON 11.625 B.C.

123215-01
SPLINE DATA
13 TEETH
8/16 D.P.
30° P.A.
1.795 MAJOR
SAE "D-E"

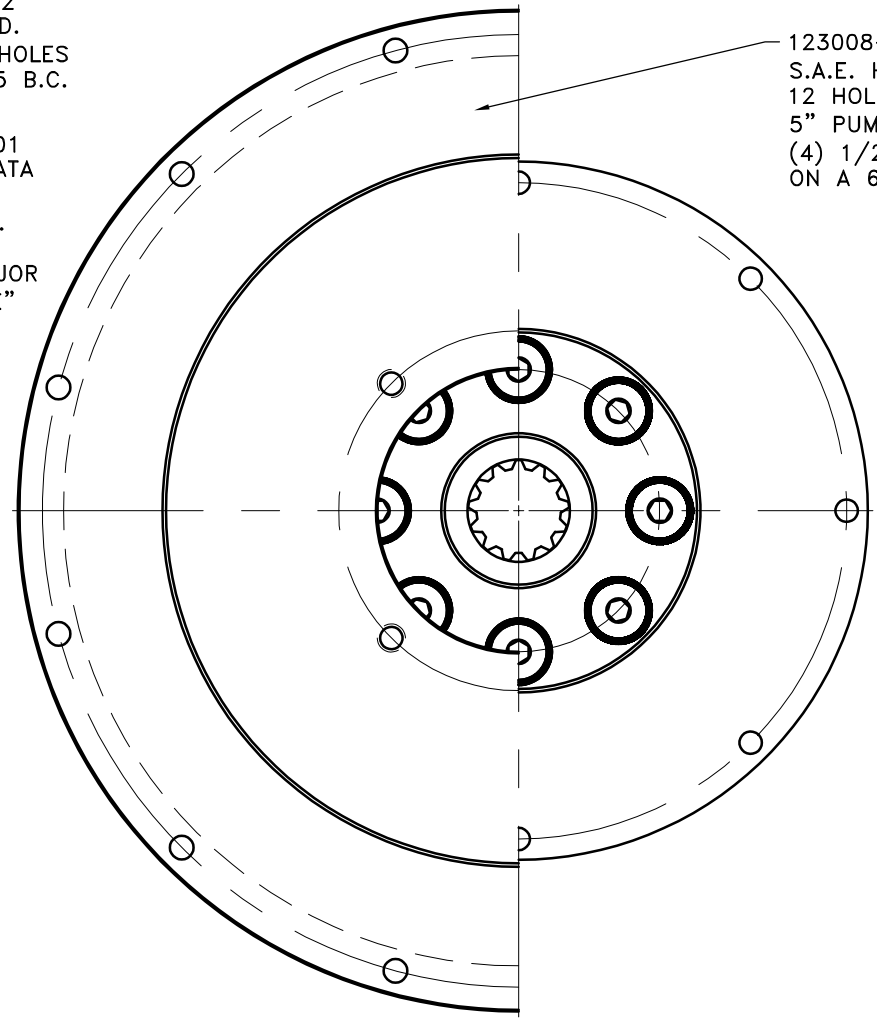

123008-DX4
S.A.E. HOUSING MOUNT 27/64 DIA DRILL THRU
12 HOLES EQUALLY SPACED ON 16.88 B.C.
5" PUMP PILOT S.A.E. "C" PUMP MOUNT
(4) 1/2-13 TAPPED HOLES EQ. SPACED
ON A 6.38 B.C.

APPLY SUPPLIED COUPLING GREASE
TO INTERNAL AND EXTERNAL SPLINE
AT ASSEMBLY

COUPLING ASS'Y #123216

UP TO 150 HP

QTY.	PART NUMBER	DESCRIPTION
1	123008-DX4	PUMP MOUNT PLATE
1	801912	GREASE
1	HP-2000-S-62	HUBBARD PLUG
8	BOLT	7/16-20x1 HHB Y D
8	123727	THREADED BUSHING
8	H62500	NEOPRENE INSERT
1	123215-01	COUPLING HUB
1	124657-02	BACKING PLATE
1	123243-22	FLYWHEEL PLATE

SYMBOLS	DET.	PART NUMBER	DESCRIPTION	QTY.
▱ FLATNESS — STRAIGHTNESS ∠ ANGULARITY ⊥ PERPENDICULARITY ∥ PARALLELISM ⊙ CONCENTRICITY ⊕ TRUE POSITION ○ ROUNDNESS Ⓢ CIRCULAR RUN OUT Ⓣ TOTAL RUN OUT Ⓜ CYLINDRICITY √ FINISH	DO NOT SCALE DRAWING TOLERANCES UNLESS OTHERWISE SPECIFIED 125 MAXIMUM ANGLE ±1/2° FRACTION ±1/32 DECIMAL .00 ±.01 .000 ±.005 .0000 ±.0005			
CLASS	MAKE: <input checked="" type="checkbox"/> BUY: <input type="checkbox"/>	DRAWN BY	DATE	DRAWING NO.
DESCRIPTION	SAE 10	SIETING	2-7-90	123461
	10,3,13T8/16,C4,150	CHECKED BY	SCALE	SHEET OF REV.

THIS DRAWING IS THE PROPERTY OF HAYES MFG. INC. AND IS LOANED SUBJECT TO THE CONDITION THAT IT SHALL NOT BE REPRODUCED, COPIED, LOANED OR OTHERWISE DISPOSED OF, DIRECTLY OR INDIRECTLY. IT SHALL BE USED AS A MEANS OF REFERENCE TO WORK FURNISHED BY THIS COMPANY ONLY AND IS NOT TO BE SUBMITTED TO OUTSIDE PARTIES FOR EXAMINATION WITHOUT OUR CONSENT.