

| REV | DATE | CHANGE DESCRIPTION | MOD.BY | CK1 | CK2 |
|-----|------------|---------------------|--------|-----|-----|
| I | 11/14/2002 | ADDED BACKING PLATE | ZS | ML | HM |

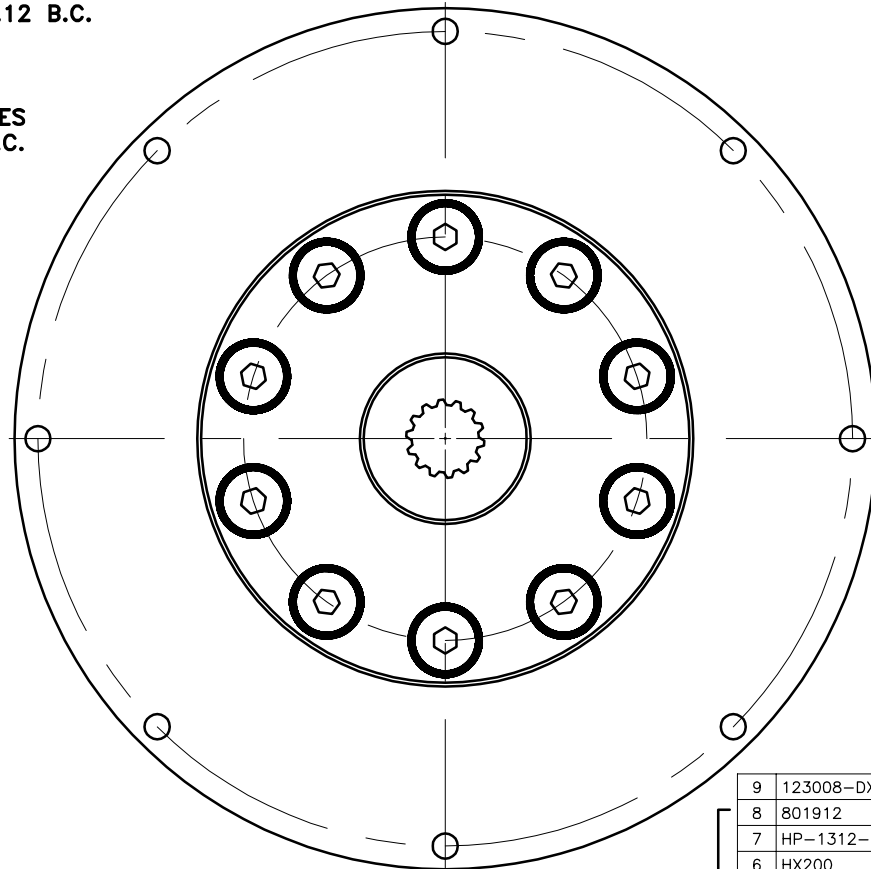
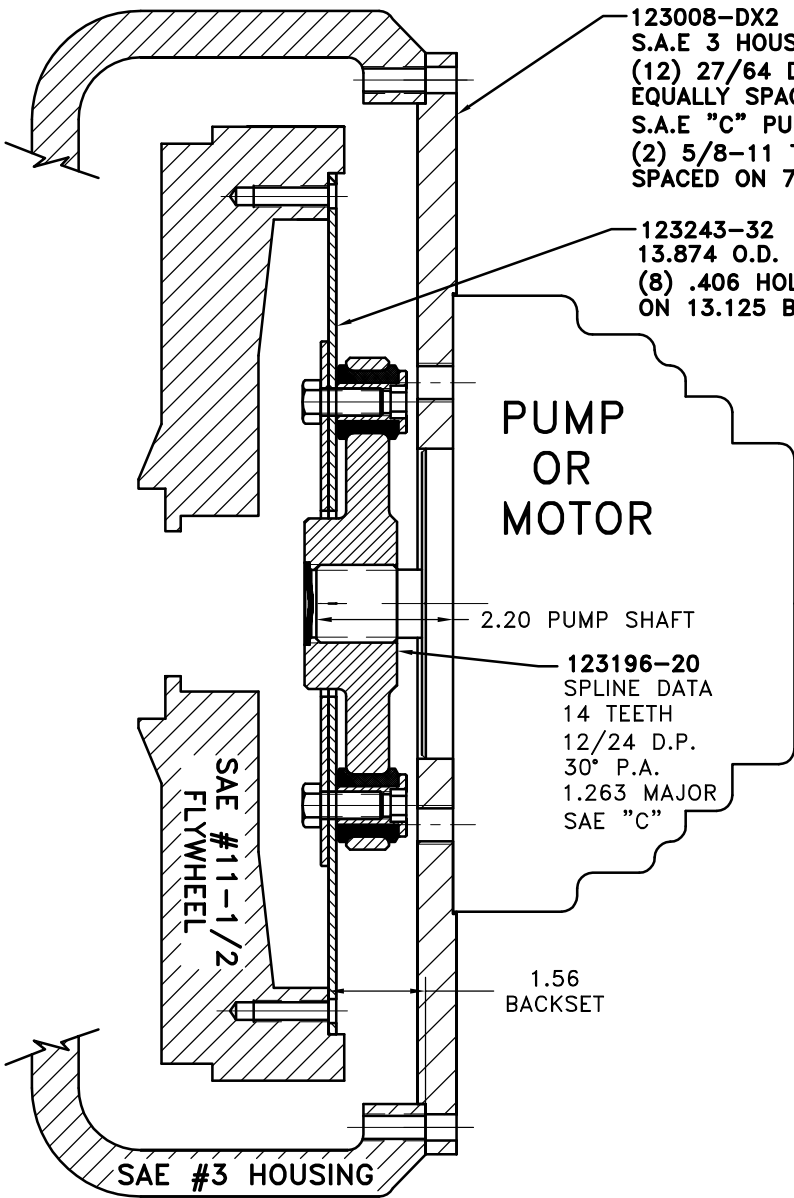

UP TO 250 HP

| QTY. | DESCRIPTION | PART NUMBER |
|------|------------------|--------------|
| 1 | FLYWHEEL PLATE | 123243-32 |
| 1 | BACKING PLATE | 124961-01 |
| 1 | COUPLING HUB | 123196-20 |
| 10 | NEOPRENE INSERT | H62500 |
| 10 | THREADED BUSHING | HX200 |
| 1 | HUBBARD PLUG | HP-1312-S-62 |
| 1 | GREASE | 801912 |
| 1 | PUMP MOUNT PLATE | 123008-DX2 |

| SYMBOLS | DET. | PART NUMBER | DESCRIPTION | QTY. |
|---|---|-----------------|--|---------------------|
| ▨ FLATNESS — STRAIGHTNESS ∟ ANGULARITY ⊥ SQUARENESS ∥ PARALLELISM ⊕ CONCENTRICITY ⊙ TRUE POSITION ○ ROUNDNESS ⊖ CIRCULAR RUN OUT ⊖ TOTAL RUN OUT ⊖ CYLINDRICITY √ FINISH | DO NOT SCALE DRAWING TOLERANCES UNLESS OTHERWISE SPECIFIED 125/ MAXIMUM ANGLE ±1/2° FRACTION ±1/32 DECIMAL .00 ±.01 .000 ±.005 .0000 ±.0005 | | HAYES MANUFACTURING INC. ® TITLE FLYWHEEL COUPLING ASS'Y WITH PUMP MOUNT PLATE MATERIAL | |
| - UNLESS OTHERWISE SPECIFIED - REMOVE FIRST THREAD ON ALL TAPPED HOLES BREAK ALL SHARP CORNERS .010 TO .020 STAMP OR MARK DRAWING NO. | DRAWN BY LANNEN | DATE 3-14-90 | DRAWING NO. 123484 | SHEET OF REV. |

THIS DRAWING IS THE PROPERTY OF HAYES MFG. INC. AND IS LOANED SUBJECT TO THE CONDITION THAT IT SHALL NOT BE REPRODUCED, COPIED, LOANED OR OTHERWISE DISPOSED OF, DIRECTLY OR INDIRECTLY. IT SHALL BE USED AS A MEANS OF REFERENCE TO WORK FURNISHED BY THIS COMPANY ONLY AND IS NOT TO BE SUBMITTED TO OUTSIDE PARTIES FOR EXAMINATION WITHOUT OUR CONSENT.