

REV	DATE	CHANGE DESCRIPTION	MOD.BY	CK1	CK2
H	11/01/2000	CHANGED GQ2 TO GX2	HAVEMAN		

123008-GX2  
S.A.E HOUSING MOUNT  
27/64 DRILL THRU 8 HOLES  
EQUALLY SPACED ON 13.13 B.C.  
5" PUMP PILOT S.A.E "C" PUMP MOUNT.  
(2) HOLES 5/8-11 TAPPED HOLES  
EQUALLY SPACED ON 7.12 B.C.

123243-03  
8.499 O.D.  
(6) .343 HOLES  
ON A 7.875 B.C.

PUMP  
OR  
MOTOR

2.20 PUMP SHAFT

SAE 8-1/2  
FLYWHEEL

1.19  
BACKSET

124732-01  
SPLINE DATA  
14 TEETH  
12/24 D.P.  
30° P.A.  
1.263 MAJOR  
SAE "C"

SAE #5 HOUSING

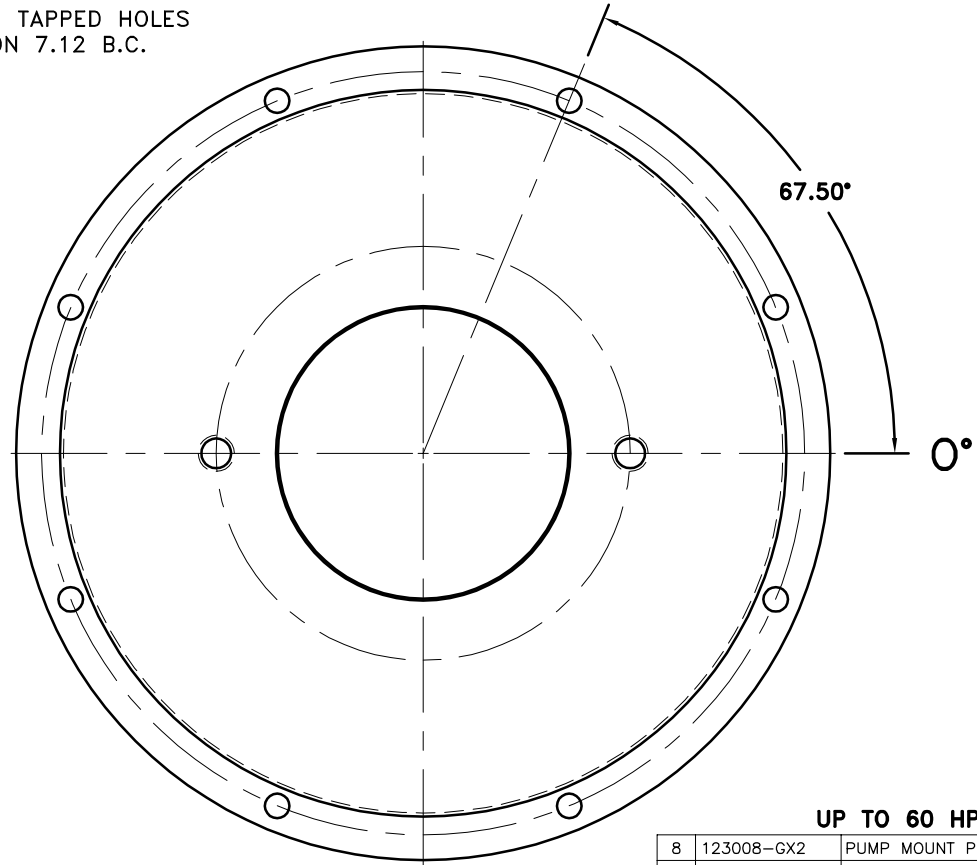

COUPLING ASS'Y  
#123192

UP TO 60 HP

QTY.	PART NUMBER	DESCRIPTION
1	123008-GX2	PUMP MOUNT PLATE
1	801912	GREASE
1	HP-1312-S-62	HUBBARD PLUG
6	HX100	5/16-24x5/8 HHB
6	123729-01	THREADED BUSHING
6	H52500	NEOPRENE INSERT
1	124732-01	COUPLING HUB
1	123243-03	FLYWHEEL PLATE

SYMBOLS	DET.	PART NUMBER	DESCRIPTION	QTY.
▨ FLATNESS — STRAIGHTNESS ∠ ANGULARITY ⊥ SQUARENESS ∥ PARALLELISM ⊕ CONCENTRICITY ⊕ TRUE POSITION ○ ROUNDNESS ⊙ CIRCULAR RUN OUT ⊙ TOTAL RUN OUT ⊙ CYLINDRICITY √ FINISH	DO NOT SCALE DRAWING TOLERANCES UNLESS OTHERWISE SPECIFIED 125/ MAXIMUM ANGLE ±1/2° FRACTION ±1/32 DECIMAL .00 ±.01 .000 ±.005 .0000 ±.0005			
			TITLE <b>FLYWHEEL COUPLING ASS'Y W/ PUMP MOUNT PLATE</b> MATERIAL	
			DRAWN BY HAVEMAN	DATE 11-27-90
			CHECKED BY RJH	SCALE
			DRAWING NO. <b>123587</b>	SHEET OF REV.

THIS DRAWING IS THE PROPERTY OF HAYES MFG. INC. AND IS LOANED SUBJECT TO THE CONDITION THAT IT SHALL NOT BE REPRODUCED, COPIED, LOANED OR OTHERWISE DISPOSED OF, DIRECTLY OR INDIRECTLY. IT SHALL BE USED AS A MEANS OF REFERENCE TO WORK FURNISHED BY THIS COMPANY ONLY AND IS NOT TO BE SUBMITTED TO OUTSIDE PARTIES FOR EXAMINATION WITHOUT OUR CONSENT.