

REV	DATE	CHANGE DESCRIPTION	MOD.BY	CK1	CK2
E2	07/18/2005	CHANGED ATTN BOX NOTE.	ZS	RJH	HM

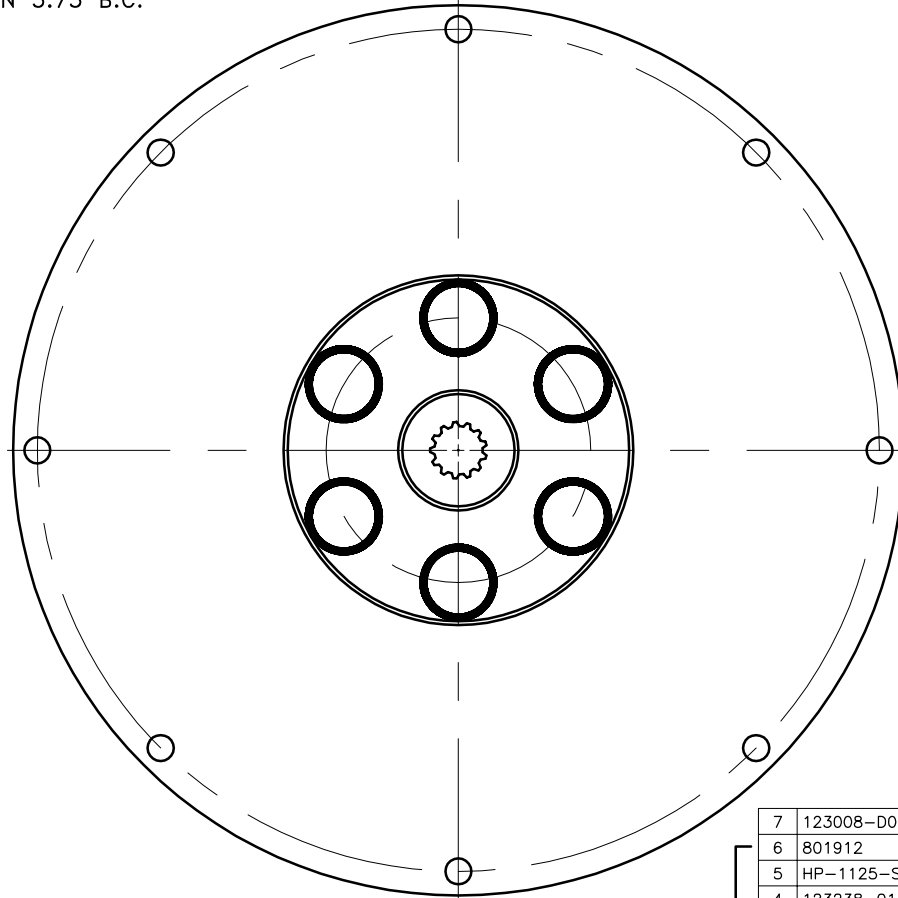
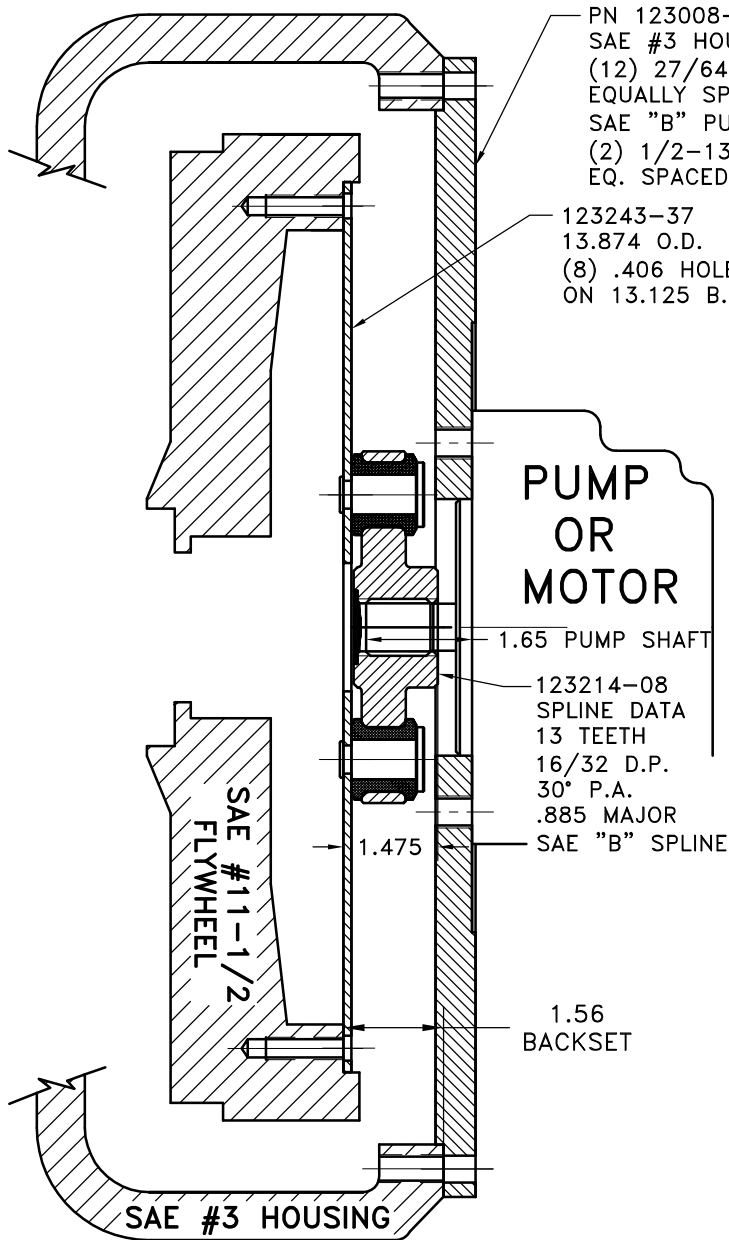

COUPLING ASS'Y
#123666

UP TO 110 HP

DET.	PART NUMBER	DESCRIPTION	QTY.
7	123008-D02	PUMP MOUNT PLATE	1
6	801912	GREASE	1
5	HP-1125-S-32	HUBBARD PLUG	1
4	123238-01	STEEL RIVET	6
3	H62500	NEOPRENE INSERTS	6
2	123214-08	COUPLING HUB	1
1	123243-37	FLYWHEEL PLATE	1

SYMBOLS	DET.	PART NUMBER	DESCRIPTION	QTY.
<ul style="list-style-type: none"> — FLATNESS — STRAIGHTNESS — ANGULARITY — SQUARENESS — PARALLELISM — CONCENTRICITY — TRUE POSITION — ROUNDNESS — CIRCULAR RUN OUT — TOTAL RUN OUT — CYLINDRICITY — FINISH 	DO NOT SCALE DRAWING TOLERANCES UNLESS OTHERWISE SPECIFIED 12/32 MAXIMUM ANGLE ±1/2° FRACTION ±1/32 DECIMAL .00 ±.01 .000 ±.005 .0000 ±.0005			
- UNLESS OTHERWISE SPECIFIED - REMOVE FIRST THREAD ON ALL TAPPED HOLES BREAK ALL SHARP CORNERS .010 TO .020 STAMP OR MARK DRAWING NO.		DRAWN BY LANNEN	DATE 12-18-91	DRAWING NO. 123793 SHEET OF REV.

THIS DRAWING IS THE PROPERTY OF HAYES MFG. INC. AND IS LOANED SUBJECT TO THE CONDITION THAT IT SHALL NOT BE REPRODUCED, COPIED, LOANED OR OTHERWISE DISPOSED OF, DIRECTLY OR INDIRECTLY. IT SHALL BE USED AS A MEANS OF REFERENCE TO WORK FURNISHED BY THIS COMPANY ONLY AND IS NOT TO BE SUBMITTED TO OUTSIDE PARTIES FOR EXAMINATION WITHOUT OUR CONSENT.