

REV	DATE	CHANGE DESCRIPTION	MOD.BY	CK1	CK2

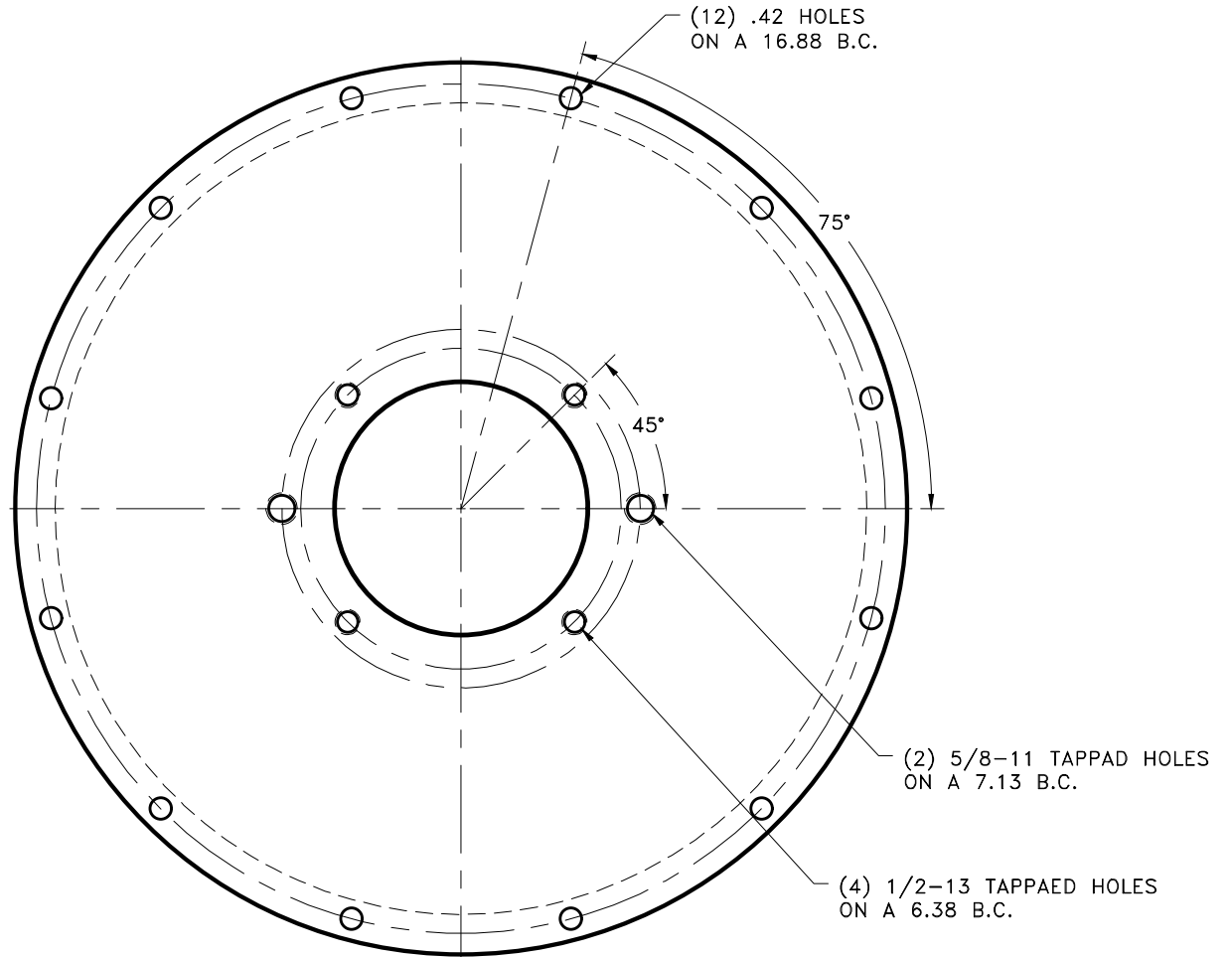
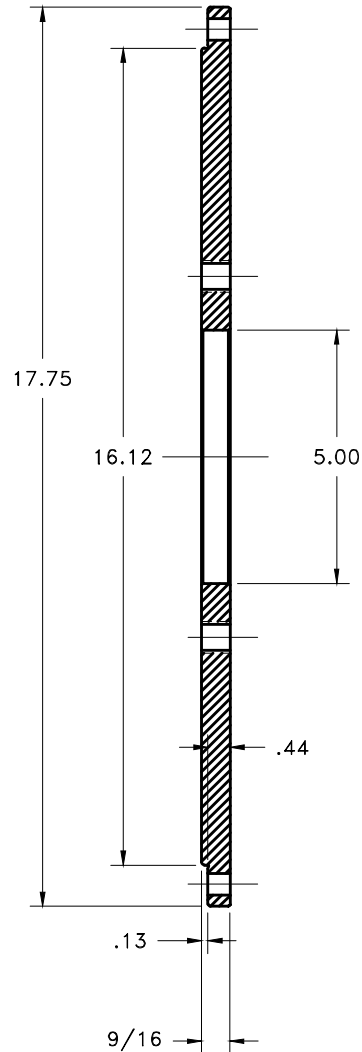

PLATING NOTE:
 1. .0002 MAX BLACK ZINC TRIVALENT
 2. PLATE ALL SURFACES

THIS DRAWING IS THE PROPERTY OF HAYES MFG. INC. AND IS LOANED SUBJECT TO THE CONDITION THAT IT SHALL NOT BE REPRODUCED, COPIED, LOANED OR OTHERWISE DISPOSED OF, DIRECTLY OR INDIRECTLY. IT SHALL BE USED AS A MEANS OF REFERENCE TO WORK FURNISHED BY THIS COMPANY ONLY AND IS NOT TO BE SUBMITTED TO OUTSIDE PARTIES FOR EXAMINATION WITHOUT OUR CONSENT.

SYMBOLS		DET.	PART NUMBER	DESCRIPTION	QTY.
	FLATNESS	DO NOT SCALE		HAYES MANUFACTURING INC. ®	
	STRAIGHTNESS	DRAWING			TITLE
	ANGULARITY	TOLERANCES UNLESS OTHERWISE SPECIFIED		PUMP MOUNT PLATE	
	PERPENDICULARITY	1/32" MAXIMUM		MATERIAL	
	PARALLELISM	ANGLE ±1/2"		STEEL	
	CONCENTRICITY	FRACTION ±1/32		CLASS	
	TRUE POSITION	DECIMAL		MAKE: <input type="checkbox"/> BUY: <input type="checkbox"/>	DRAWN BY
	ROUNDNESS	.00 ±.01		DATE	03-01-2010
	CIRCULAR RUN OUT	.0000 ±.0005		CHECKED BY	RJH
	TOTAL RUN OUT	.0000 ±.0005		SCALE	
	CYLINDRICITY				DRAWING NO.
	FINISH				123845-02ZB
					SHEET OF REV.