

REV	DATE	CHANGE DESCRIPTION	MOD.BY	CK1	CK2

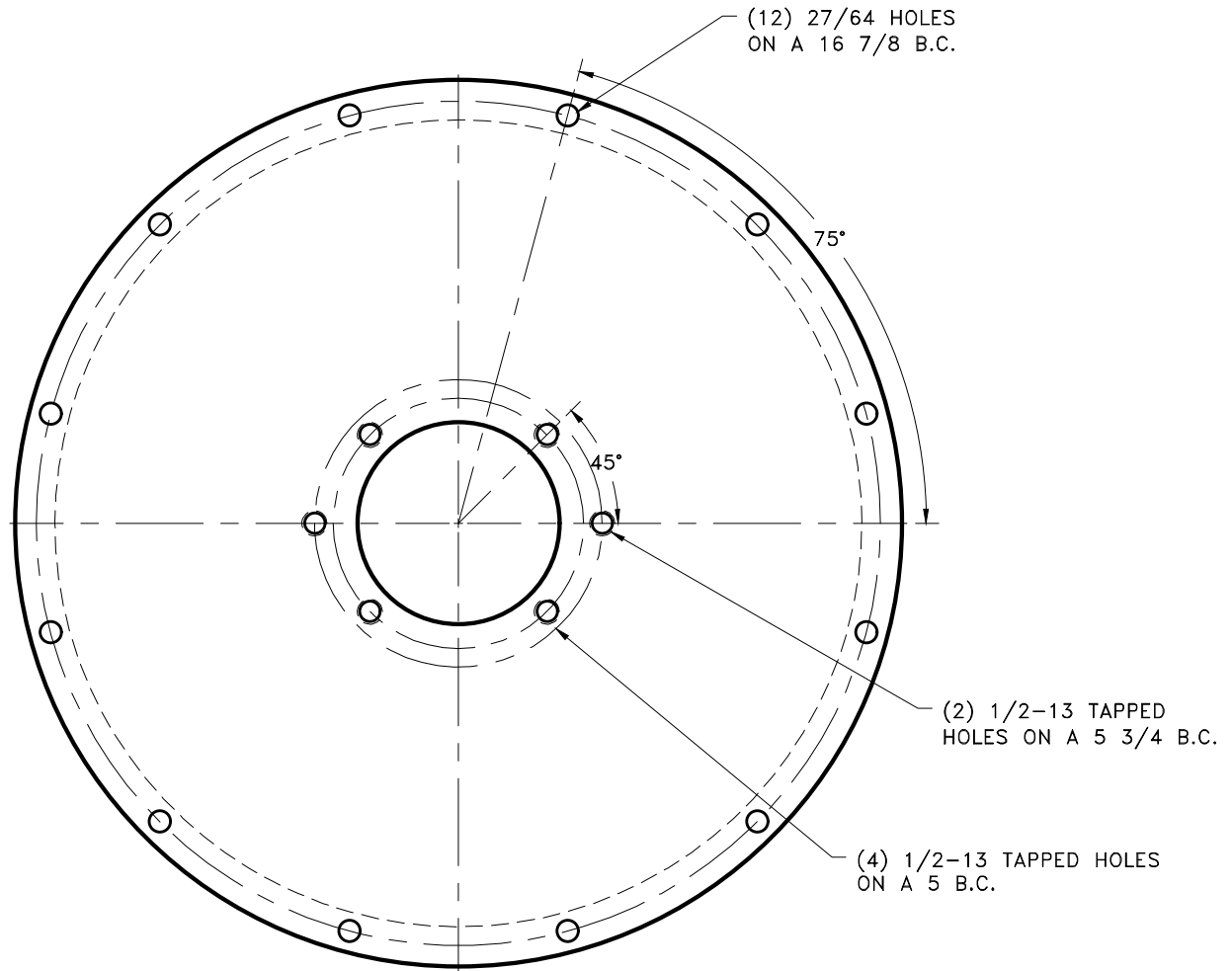
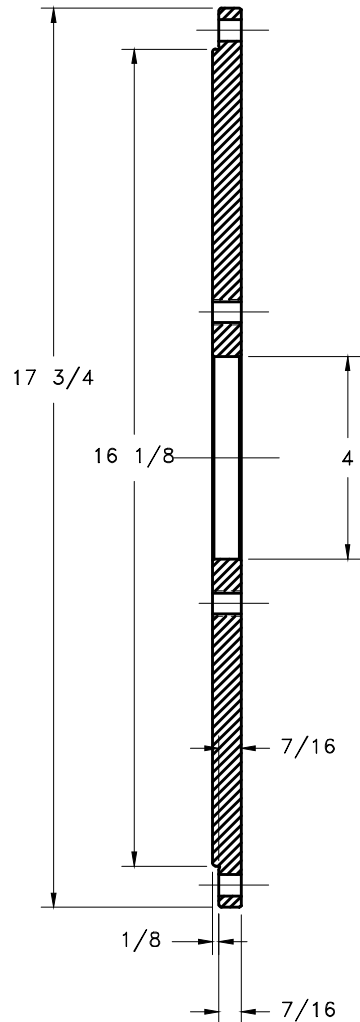

PLATING NOTE:
 1. .0002 MAX BLACK ZINC TRIVALENT
 2. PLATE ALL SURFACES

THIS DRAWING IS THE PROPERTY OF HAYES MFG. INC. AND IS LOANED SUBJECT TO THE CONDITION THAT IT SHALL NOT BE REPRODUCED, COPIED, LOANED OR OTHERWISE DISPOSED OF, DIRECTLY OR INDIRECTLY. IT SHALL BE USED AS A MEANS OF REFERENCE TO WORK FURNISHED BY THIS COMPANY ONLY AND IS NOT TO BE SUBMITTED TO OUTSIDE PARTIES FOR EXAMINATION WITHOUT OUR CONSENT.

SYMBOLS		DET.	PART NUMBER	DESCRIPTION	QTY.
	FLATNESS	DO NOT SCALE		HAYES MANUFACTURING INC. ®	
	STRAIGHTNESS	DRAWING			
	ANGULARITY	TOLERANCES UNLESS OTHERWISE SPECIFIED		TITLE	PUMP MOUNT PLATE
	PERPENDICULARITY	1/32" MAXIMUM		MATERIAL	STEEL
	PARALLELISM	ANGLE ±1/2°		CLASS	MAKE: <input type="checkbox"/> BUY: <input type="checkbox"/>
	CONCENTRICITY	FRACTION ±1/32		DESCRIPTION	
	TRUE POSITION	DECIMAL		DRAWN BY	DATE
	ROUNDNESS	.00 ±.01		SIETING	03-01-2010
	CIRCULAR RUN OUT	.0000 ±.005		CHECKED BY	SCALE
	TOTAL RUN OUT	.0000 ±.0005		DRAWING NO.	123845-03ZB
	CYLINDRICITY			SHEET	OF
	FINISH			REV.	