

CUSTOMER DRAWING

REVISIONS						
ZONE	REV.	DESCRIPTION	DATE	APR 1	APR 2	DCR #
	D	RELEASED IN SW; UPDTAED TO PILOTED BUSHINGS	11/13/23			4295

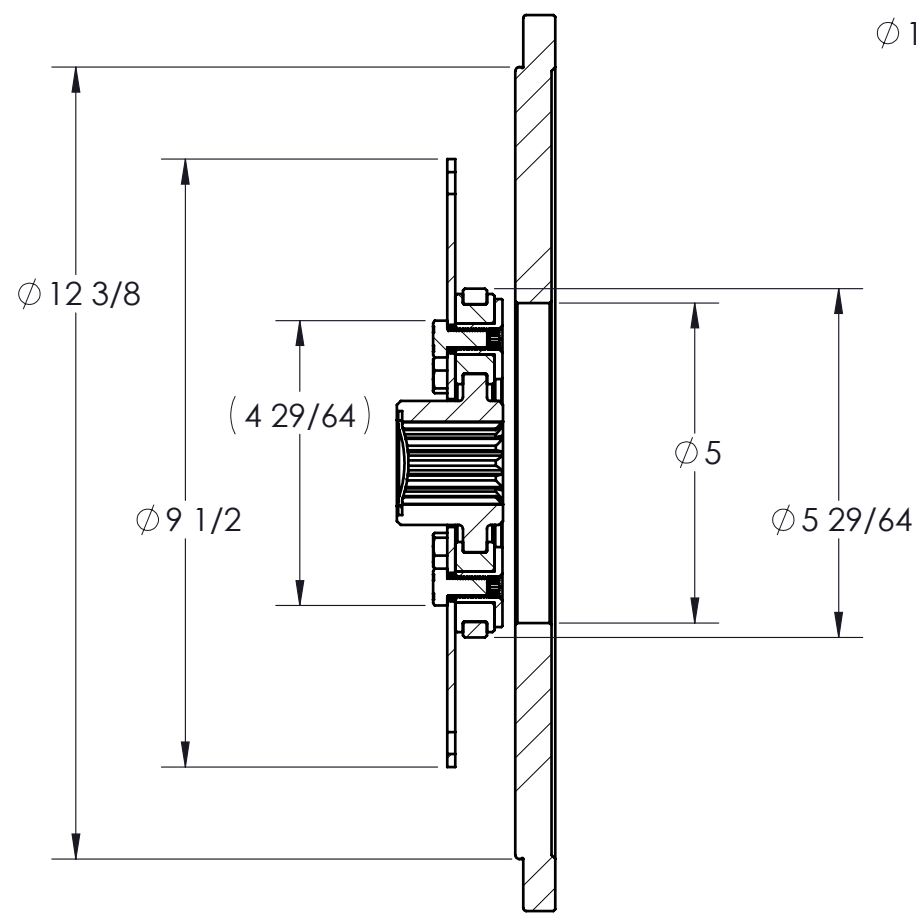

SECTION B-B

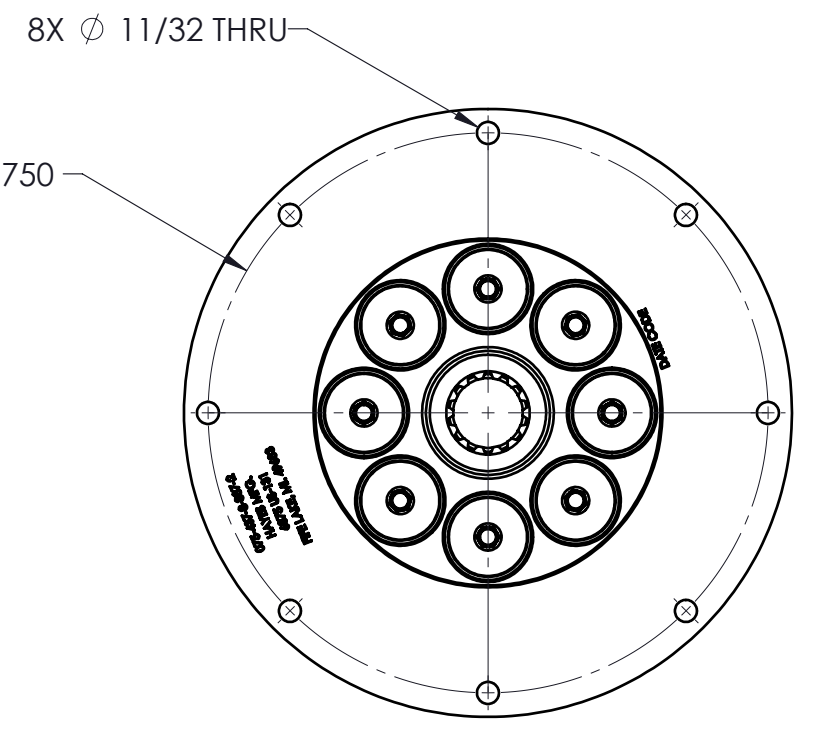
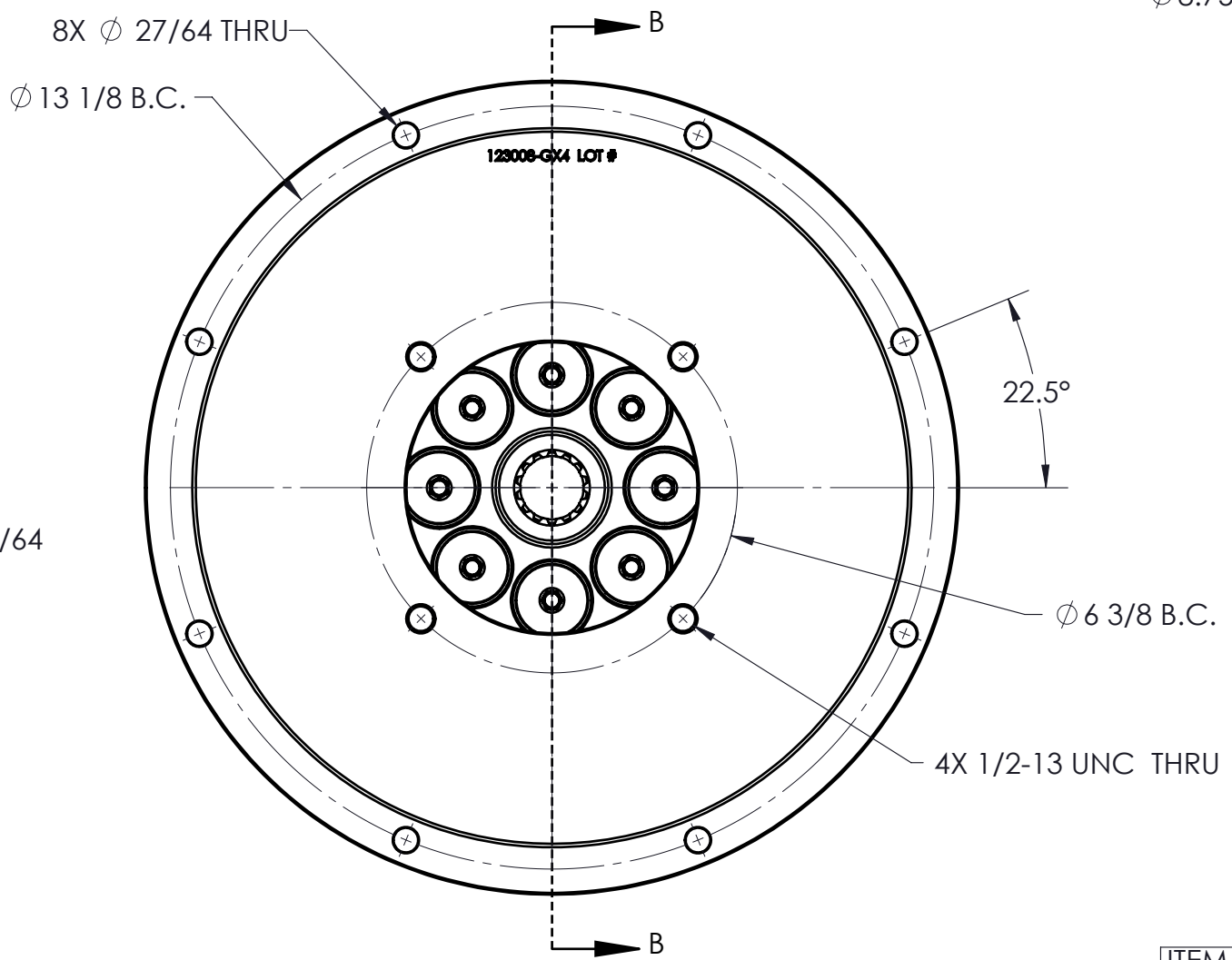

COUPLING FRONT VIEW

**COUPLING IS NOT SERVICEABLE**

PUMP DRIVE SPECS	
FLYWHEEL	SAE 7.5
HOUSING	SAE 5
PUMP FLANGE	SAE C 4-BOLT
PUMP SHAFT	14T 12/24 "C"
HP RATING (@1800 RPM)	75

**PROPRIETARY AND CONFIDENTIAL**  
 THE INFORMATION CONTAINED IN THIS DRAWING IS THE SOLE PROPERTY OF HAYES MANUFACTURING. ANY REPRODUCTION IN PART OR AS A WHOLE WITHOUT THE WRITTEN PERMISSION OF HAYES MANUFACTURING IS PROHIBITED.

UNLESS OTHERWISE SPECIFIED: DIMENSIONS ARE IN INCHES TOLERANCES: FRACTIONAL ± 1/32 ANGULAR: MACH ± 1/2° TWO DECIMAL ± 0.01 THREE DECIMAL ± 0.005 FOUR DECIMAL ± 0.0005			SYMBOLS ▱ FLATNESS    ⊙ CONCENTRICITY    ⊔ COUNTERBORE ○ ROUNDNESS    ⊕ TRUE POSITION    ∇ COUNTERSINK // PARALLELISM    ⊥ PERPENDICULARITY    ∅ HOLE DEPTH ∅ DIAMETER    ↗ CIRCULAR RUN OUT    = SYMMETRIC "R" RADIUS    ↗ TOTAL RUN OUT		
CLASS	SAE 7.5		NAME	DATE	
DESCRIPTION	7-1 1/2, 14T12/24, C4, 75		DRAWN	SIETING 1/13/2023	
MAKE	WEIGHT	HEAT TREAT	PCM APPR.		
X BUY	26.0 LB		ENG APPR.		
	VOLUME	FINISH	SHIP. APPR.		
	CU. IN.		QA APPR.		
			MATERIAL		

ITEM NO.	PART NUMBER	DESCRIPTION	QTY.
1	124437	FLYWHEEL COUPLING ASSY.	1
2	123008-GX4	PUMP MOUNT PLATE	1

**HAYES**

TITLE: FLYWHEEL COUPLING ASM W/ PUMP MOUNT PLATE

DWG. NO. 124436    REV D

DO NOT SCALE    SHEET 1 OF 4