

123008-G02  
 S.A.E HOUSING MOUNT 27/64 DRILL  
 THRU 8 HOLES EQUALLY SPACED  
 ON 13.13 B.C. 4" PUMP PILOT  
 S.A.E "B,B-B" PUMP MOUNT.  
 (2) HOLES 1/2-13 TAPPED HOLES EQUALLY  
 SPACED ON 5.75 B.C. FOR PUMP MOUNT.  
 HOLES OUT OF ROTATION 90°

124243-21  
 9.499 O.D.  
 (8) .343 HOLES  
 ON 8.750 B.C.

PUMP OR MOTOR  
 1.81  
 SHAFT LENGTH  
 1.000 DIA SHAFT  
 1/4 KEYWAY

FLYWHEEL  
 SAE #7 1/2

HOUSING SAE #5

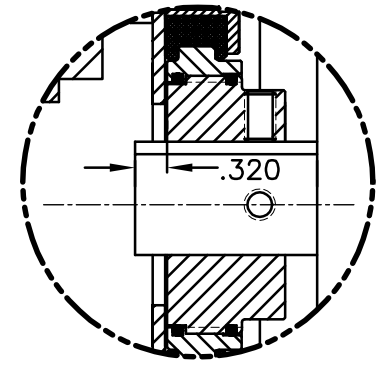

PRESET HUB TO  
 THIS LENGTH  
VIEW A

COUPLING ASS'Y #124512

11	123008-G02	PUMP MTG. PLATE	1
11	PURCHASE	5/16-18-5/8 S.S.S.C.P	1
10	PURCHASE	5/16-18-1/2 S.S.S.C.P	1
9	801912	GREASE	1
8	568-143	O-RING (124282-02)	1
7	568-142	O-RING (124284-11)	1
6	HX100	5/16-18-24-5/8 BOLT	6
5	123729-01	THREADED BUSHING	6
4	H52500	NEOPRENE INSERT	6
3	124284-11	EXTERNAL SPLINED ADAPTER	1
2	124282-02	INTERNAL SPLINED HUB	1
1	124243-21	FLYWHEEL PLATE	1

SYMBOLS FLATNESS STRAIGHTNESS ANGULARITY SQUARENESS PARALLELISM CONCENTRICITY TRUE POSITION SYMMETRY LOC. SURFACE ROUNDNESS RUN OUT FINISH	DO NOT SCALE DRAWING TOLERANCES UNLESS OTHERWISE SPECIFIED HOLE ±.002 FRACTION ±1/32 DECIMAL .05 ±.010 .005 ±.005 .0005 ±.0005		
	- UNLESS OTHERWISE SPECIFIED - REMOVE FIRST THREADS ON ALL TAPPED HOLES BREAK ALL SHARP CORNERS .010 TO .020 STAMP OR MARK DRAWING NO.	DRAWN BY <b>HAVEMAN</b>	DATE <b>7-15-96</b>
	CHECKED BY	SCALE	SHEET OF REV.

THIS DRAWING IS THE PROPERTY OF HAYES MFG. INC. AND IS LOANED  
 SUBJECT TO THE CONDITION THAT IT SHALL NOT BE REPRODUCED,  
 COPIED, LOANED OR OTHERWISE DISPOSED OF, DIRECTLY OR INDIRECTLY.  
 IT SHALL BE USED AS A MEANS OF REFERENCE TO WORK FURNISHED BY  
 THIS COMPANY ONLY AND IS NOT TO BE SUBMITTED TO OUTSIDE PARTIES  
 FOR EXAMINATION WITHOUT OUR CONSENT.