

REV	DATE	CHANGE DESCRIPTION	MOD.BY	CK1	CK2
B1	05/04/2006	ADDED NOTES TO ATTN BOX.	ZS		

PT# 123008-AS4
 S.A.E HOUSING MOUNT
 27/64 DRILL THUR 12 HOLES
 EQUALLY SPACED ON 20.88 B.C.
 6.00" PUMP PILOT. S.A.E "D" PUMP MOUNT.
 (4) 3/4-10 TAPPED HOLE EQUALLY
 SPACED ON 9.00 B.C.

123243-39
 18.375 O.D.
 (8) .531 HOLES
 ON 17.250 B.C.

123196-14
 SPLINE DATA
 13 TEETH
 8/16 D.P.
 30° P.A.
 1.795 MAJOR
 SAE "D-E"

PUMP
 OR
 MOTOR

2.93 SHAFT LENGTH

SAE #14 FLYWHEEL

1.000
 BACKSET

SAE #1 HOUSING

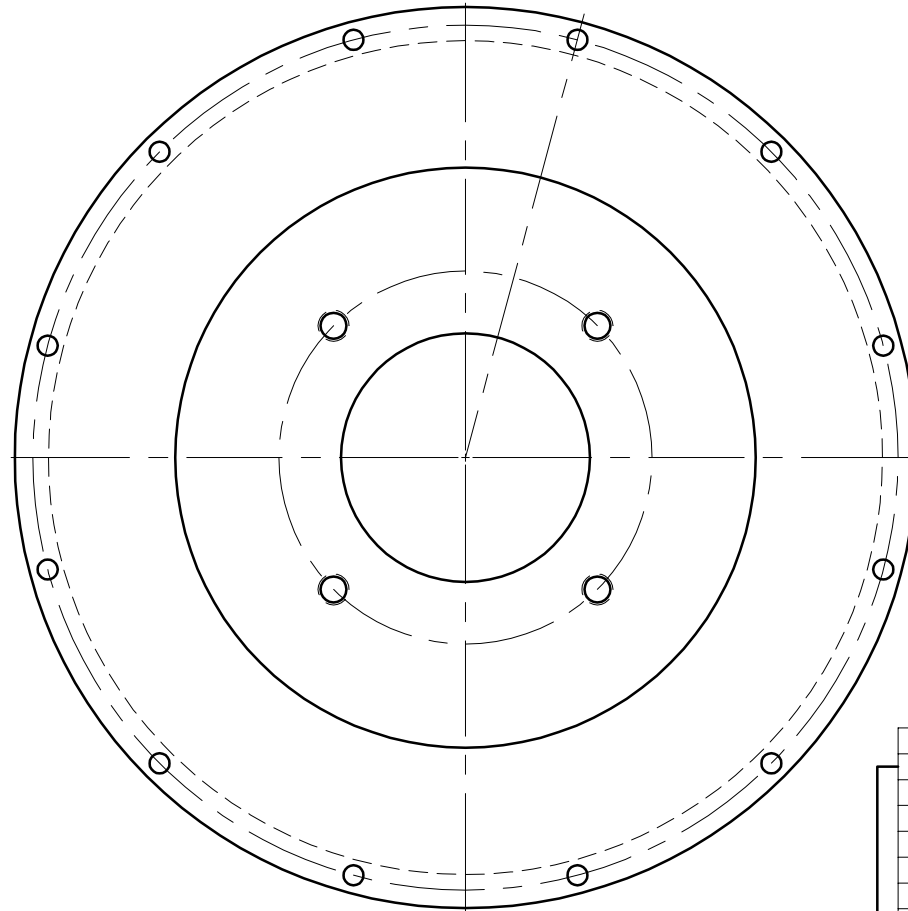

COUPLING ASS'Y #123523

UP TO 350 HP

9	123008-AS4	PUMP MOUNT PLATE	1
8	801912	GREASE	1
7	HP-2000-S-62	HUBBARD PLUG	1
6	HX200	7/16-20 x 1" HHB	12
5	123727	THREADED BUSHING	12
4	H62500	NEOPRENE INSERT	12
3	123196-14	COUPLING HUB	1
2	124961-02	BACKING PLATE	1
1	123243-39	FLYWHEEL PLATE	1

SYMBOLS	DET.	PART NUMBER	DESCRIPTION	QTY.
▨ FLATNESS — STRAIGHTNESS ∟ ANGULARITY ⊥ SQUARENESS ∥ PARALLELISM ⊕ CONCENTRICITY ⊙ TRUE POSITION ○ ROUNDNESS ⊙ CIRCULAR RUN OUT ⊙ TOTAL RUN OUT ⊙ CYLINDRICITY ✓ FINISH	DO NOT SCALE DRAWING TOLERANCES UNLESS OTHERWISE SPECIFIED 12/32 MAXIMUM ANGLE ±1/2° FRACTION ±1/32 DECIMAL .00 ±.01 .000 ±.005 .0000 ±.0005			
- UNLESS OTHERWISE SPECIFIED - REMOVE FIRST THREAD ON ALL TAPPED HOLES BREAK ALL SHARP CORNERS .010 TO .020 STAMP OR MARK DRAWING NO.			TITLE FLYWHEEL COUPLING ASS'Y W/ PUMP MOUNT PLATE MATERIAL	DRAWN BY SIETING CHECKED BY RJH
		DATE 12-03-96 SCALE	DRAWING NO. 124605 SHEET OF REV.	

THIS DRAWING IS THE PROPERTY OF HAYES MFG. INC. AND IS LOANED
 SUBJECT TO THE CONDITION THAT IT SHALL NOT BE REPRODUCED,
 COPIED, LOANED OR OTHERWISE DISPOSED OF, DIRECTLY OR INDIRECTLY.
 IT SHALL BE USED AS A MEANS OF REFERENCE TO WORK FURNISHED BY
 THIS COMPANY ONLY AND IS NOT TO BE SUBMITTED TO OUTSIDE PARTIES
 FOR EXAMINATION WITHOUT OUR CONSENT.