

REV	DATE	CHANGE DESCRIPTION	MOD. BY	CK1	CK2
A1	02/20/2003	FIXED D.P. ON SPLINE NOTE.	ZS	RJH	HM

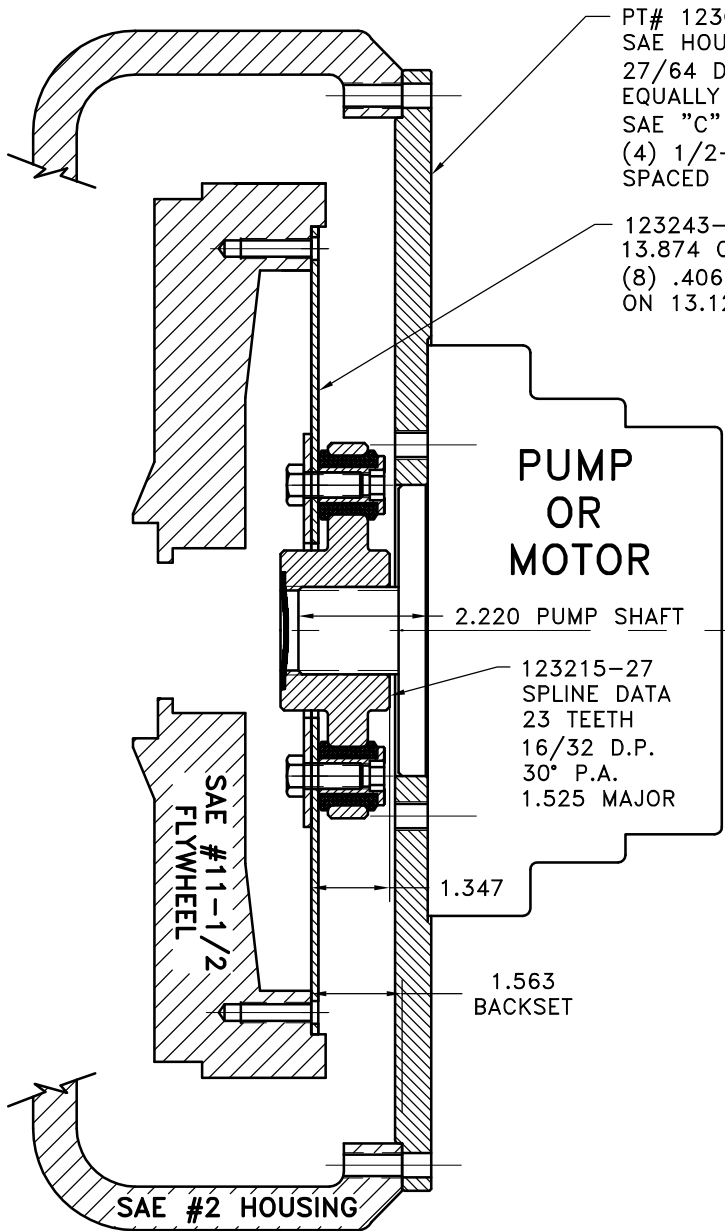

PT# 123008-CX4
 SAE HOUSING MOUNT
 27/64 DRILL THRU 12 HOLES
 EQUALLY SPACED ON 18.38 B.C.
 SAE "C" PUMP MOUNT. 5" PUMP PILOT.
 (4) 1/2-13 TAPPED HOLES EQUALLY
 SPACED ON 6.38 B.C.

123243-31
 13.874 O.D.
 (8) .406 HOLES
 ON 13.125 B.C.

PUMP
 OR
 MOTOR

123215-27
 SPLINE DATA
 23 TEETH
 16/32 D.P.
 30° P.A.
 1.525 MAJOR

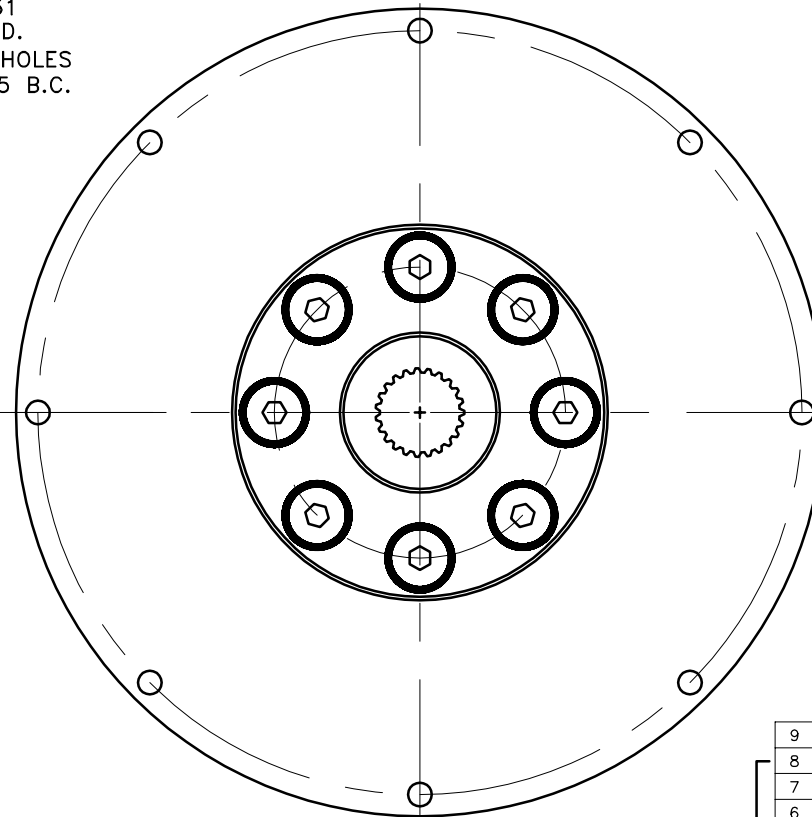

COUPLING ASS'Y
 #124742

UP TO 150 HP

QTY.	PART NUMBER	DESCRIPTION
1	123008-CX4	PUMP MOUNT PLATE [2]
1	801912	GREASE
1	HP-1625-S-62	HUBBARD PLUG
8	HX200	7/16-20x1 HHB
8	123727	THREADED BUSHING
8	H62500	NEOPRENE INSERT
1	123215-27	COUPLING HUB [23 16/32\5.000]
1	124657-02	BACKING PLATE
1	123243-31	FLYWHEEL PLATE [11.5\5.000]

SYMBOLS	DET.	PART NUMBER	DESCRIPTION	QTY.
▨ FLATNESS — STRAIGHTNESS ∠ ANGULARITY ⊥ SQUARENESS ∥ PARALLELISM ⊕ CONCENTRICITY ⊙ TRUE POSITION ○ ROUNDNESS ⊖ CIRCULAR RUN OUT ⊖ TOTAL RUN OUT ⊖ CYLINDRICITY √ FINISH	DO NOT SCALE DRAWING TOLERANCES UNLESS OTHERWISE SPECIFIED 1/32" MAXIMUM ANGLE ±1/2° FRACTION ±1/32 DECIMAL .00 ±.01 .000 ±.005 .0000 ±.0005			
- UNLESS OTHERWISE SPECIFIED - REMOVE FIRST THREAD ON ALL TAPPED HOLES BREAK ALL SHARP CORNERS .010 TO .020 STAMP OR MARK DRAWING NO.			TITLE FLYWHEEL COUPLING ASS'Y & PUMP MOUNT PLATE MATERIAL	DRAWN BY HAVEMAN DATE 7-14-97 CHECKED BY SCALE
			DRAWING NO. 124741 SHEET OF REV.	

THIS DRAWING IS THE PROPERTY OF HAYES MFG. INC. AND IS LOANED SUBJECT TO THE CONDITION THAT IT SHALL NOT BE REPRODUCED, COPIED, LOANED OR OTHERWISE DISPOSED OF, DIRECTLY OR INDIRECTLY. IT SHALL BE USED AS A MEANS OF REFERENCE TO WORK FURNISHED BY THIS COMPANY ONLY AND IS NOT TO BE SUBMITTED TO OUTSIDE PARTIES FOR EXAMINATION WITHOUT OUR CONSENT.