

PT# 123008-CX2  
SAE HOUSING MOUNT  
27/64 DRILL THRU 12 HOLES  
EQUALLY SPACED ON 18.38 B.C.  
SAE "C" PUMP MOUNT. 5" PUMP PILOT.  
(2) 5/8-11 TAPPED HOLES EQUALLY  
SPACED ON 7.125 B.C.

123243-32  
13.874 O.D  
(8) .406 HOLES  
ON 13.125 B.C.

PUMP  
OR  
MOTOR

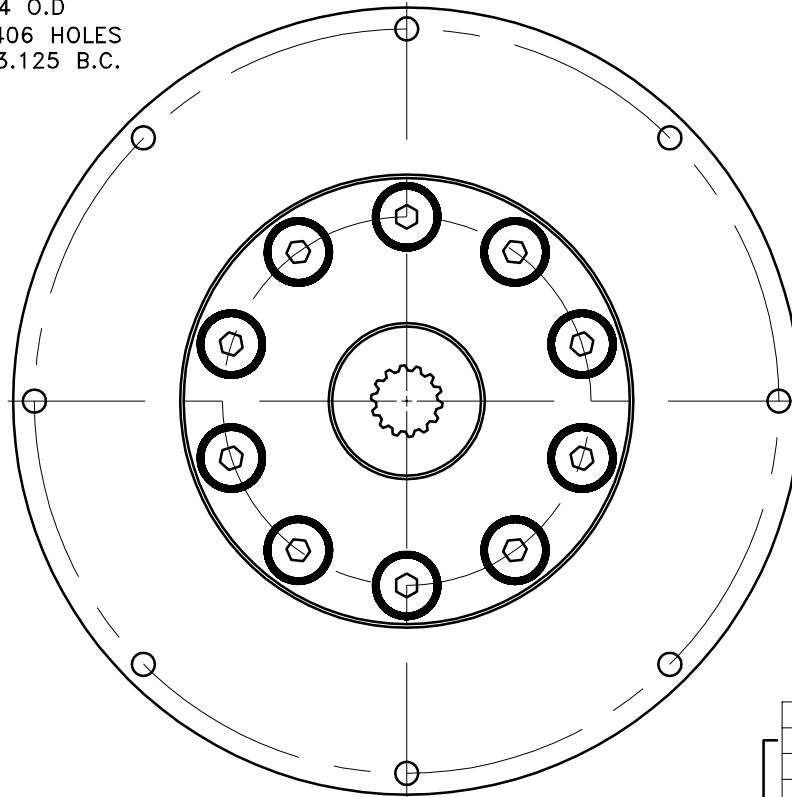

COUPLING ASS'Y  
#123485

UP TO 250 HP

REV. NO.	SYM.	DATE	CHANGE DESCRIPTION	DWN.
000138	A	11/00	CHANGED CQ2 TO CX2	RH
	B	11/00	ADDED BACKING PLATE	RH

QTY.	PART NUMBER	DESCRIPTION
1	123008-CX2	PUMP MOUNT PLATE
1	801912	GREASE
1	HP-1312-S-62	HUBBARD PLUG
10	HX200	7/16-20x1 HHB
10	123727	THREADED BUSHING
10	H62500	NEOPRENE INSERT
1	123196-20	COUPLING HUB
1	124961-01	BACKING PLATE
1	123243-32	FLYWHEEL PLATE

SYMBOLS	DET.	PART NUMBER	DESCRIPTION	QTY.
▨ FLATNESS — STRAIGHTNESS ∠ ANGULARITY ⊥ SQUARENESS ∥ PARALLELISM ⊕ CONCENTRICITY ⊙ TRUE POSITION ○ ROUNDNESS ⊙ CIRCULAR RUN OUT ⊙ TOTAL RUN OUT ⊙ CYLINDRICITY √ FINISH	DO NOT SCALE DRAWING TOLERANCES UNLESS OTHERWISE SPECIFIED ANGLE ±1/2° FRACTION ±1/32 DECIMAL .00 ±.01 .000 ±.005 .0000 ±.0005		 HAYES TM MANUFACTURING INC.	
			TITLE FLYWHEEL COUPLING ASS'Y WITH PUMP MOUNT PLATE MATERIAL	
			DRAWN BY HAVEMAN	DATE 9-3-98
			CHECKED BY SCALE	DRAWING NO. 125195 SHEET OF REV.
			- UNLESS OTHERWISE SPECIFIED - REMOVE FIRST THREAD ON ALL TAPPED HOLES BREAK ALL SHARP CORNERS .010 TO .020 STAMP OR MARK DRAWING NO.	

THIS DRAWING IS THE PROPERTY OF HAYES MFG. INC. AND IS LOANED  
SUBJECT TO THE CONDITION THAT IT SHALL NOT BE REPRODUCED,  
COPIED, LOANED OR OTHERWISE DISPOSED OF, DIRECTLY OR INDIRECTLY.  
IT SHALL BE USED AS A MEANS OF REFERENCE TO WORK FURNISHED BY  
THIS COMPANY ONLY AND IS NOT TO BE SUBMITTED TO OUTSIDE PARTIES  
FOR EXAMINATION WITHOUT OUR CONSENT.