

REV. NO.	SYM.	DATE	CHANGE DESCRIPTION	DWN.
000051	A	1/99	CHANGED SAE DESCRIPTION	RH
000138	B	12/00	CHANGED 123008-DQ4 TO DX4	RH

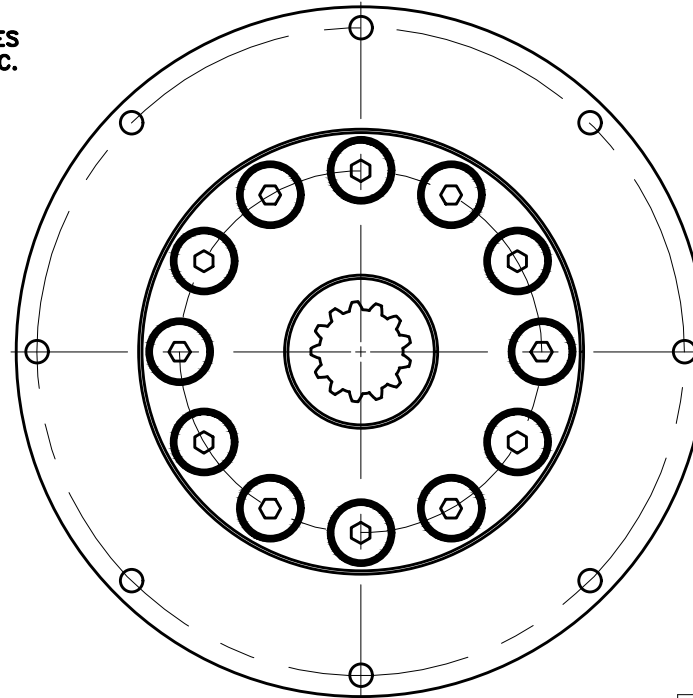
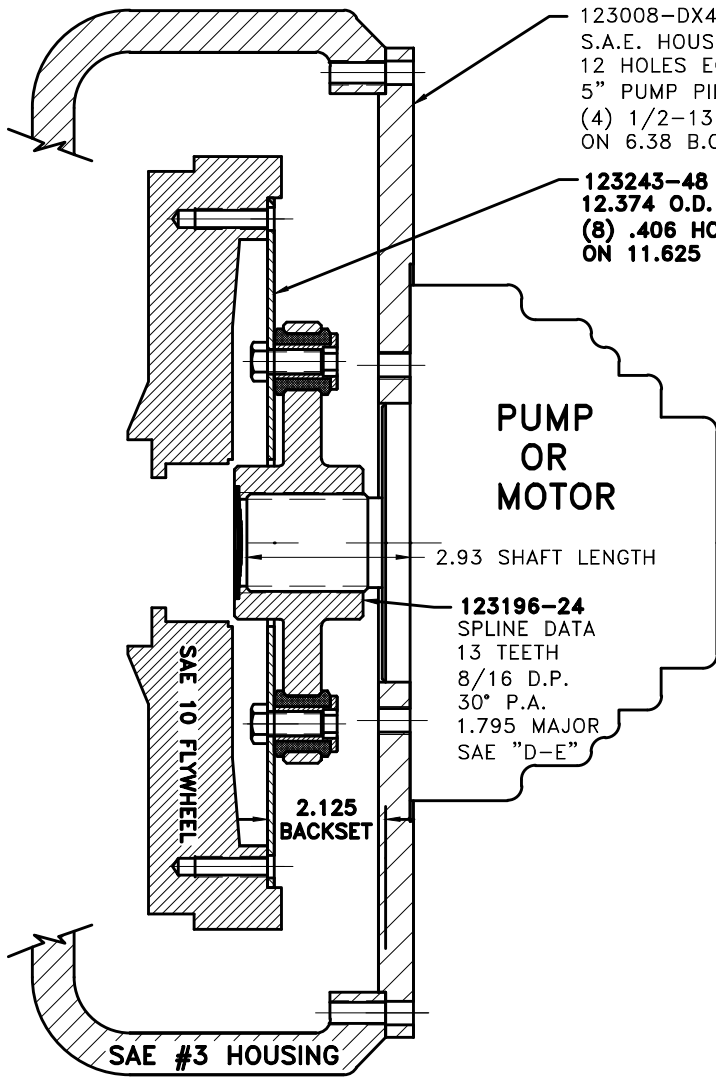

**COUPLING ASS'Y  
#125214**

**UP TO 350 HP**

QTY.	DESCRIPTION	PART NUMBER	DET.
1	PUMP MOUNT PLATE	123008-DX4	8
1	GREASE	801912	7
1	HUBBARD PLUG	HP-2000-S-62	6
12	7/16-20x1 HHB	HX200	5
12	THREADED BUSHING	123727	4
12	NEOPRENE INSERT	H62500	3
1	COUPLING HUB	123196-24	2
1	FLYWHEEL PLATE	123243-48	1

SYMBOLS		DET.	PART NUMBER	DESCRIPTION	QTY.
	FLATNESS				
	STRAIGHTNESS				
	ANGULARITY				
	SQUARENESS				
	PARALLELISM				
	CONCENTRICITY				
	TRUE POSITION				
	ROUNDNESS				
	CIRCULAR RUN OUT				
	TOTAL RUN OUT				
	CYLINDRICITY				
	FINISH				

DO NOT SCALE DRAWING		TOLERANCES UNLESS OTHERWISE SPECIFIED	
ANGLE ±1/2'	FRACTION ±1/32		
DECIMAL	.00 ±.01		
	.000 ±.005		
	.0000 ±.0005		
- UNLESS OTHERWISE SPECIFIED - REMOVE FIRST THREAD ON ALL TAPPED HOLES		DRAWN BY	DATE
BREAK ALL SHARP CORNERS .010 TO .020 STAMP OR MARK DRAWING NO.		HAVEMAN	9-21-98
		CHECKED BY	SCALE

<b>HAYES</b> TM MANUFACTURING INC.	
TITLE FLYWHEEL COUPLING ASS'Y WITH PUMP MOUNT PLATE	
MATERIAL	
DRAWING NO.	125213
SHEET	OF REV.

THIS DRAWING IS THE PROPERTY OF HAYES MFG. INC. AND IS LOANED SUBJECT TO THE CONDITION THAT IT SHALL NOT BE REPRODUCED, COPIED, LOANED OR OTHERWISE DISPOSED OF, DIRECTLY OR INDIRECTLY. IT SHALL BE USED AS A MEANS OF REFERENCE TO WORK FURNISHED BY THIS COMPANY ONLY AND IS NOT TO BE SUBMITTED TO OUTSIDE PARTIES FOR EXAMINATION WITHOUT OUR CONSENT.