

REV	DATE	CHANGE DESCRIPTION	MOD.BY	CK1	CK2
A	10/16/2001	CHANGED PLATE TO 124243-80	ZS		

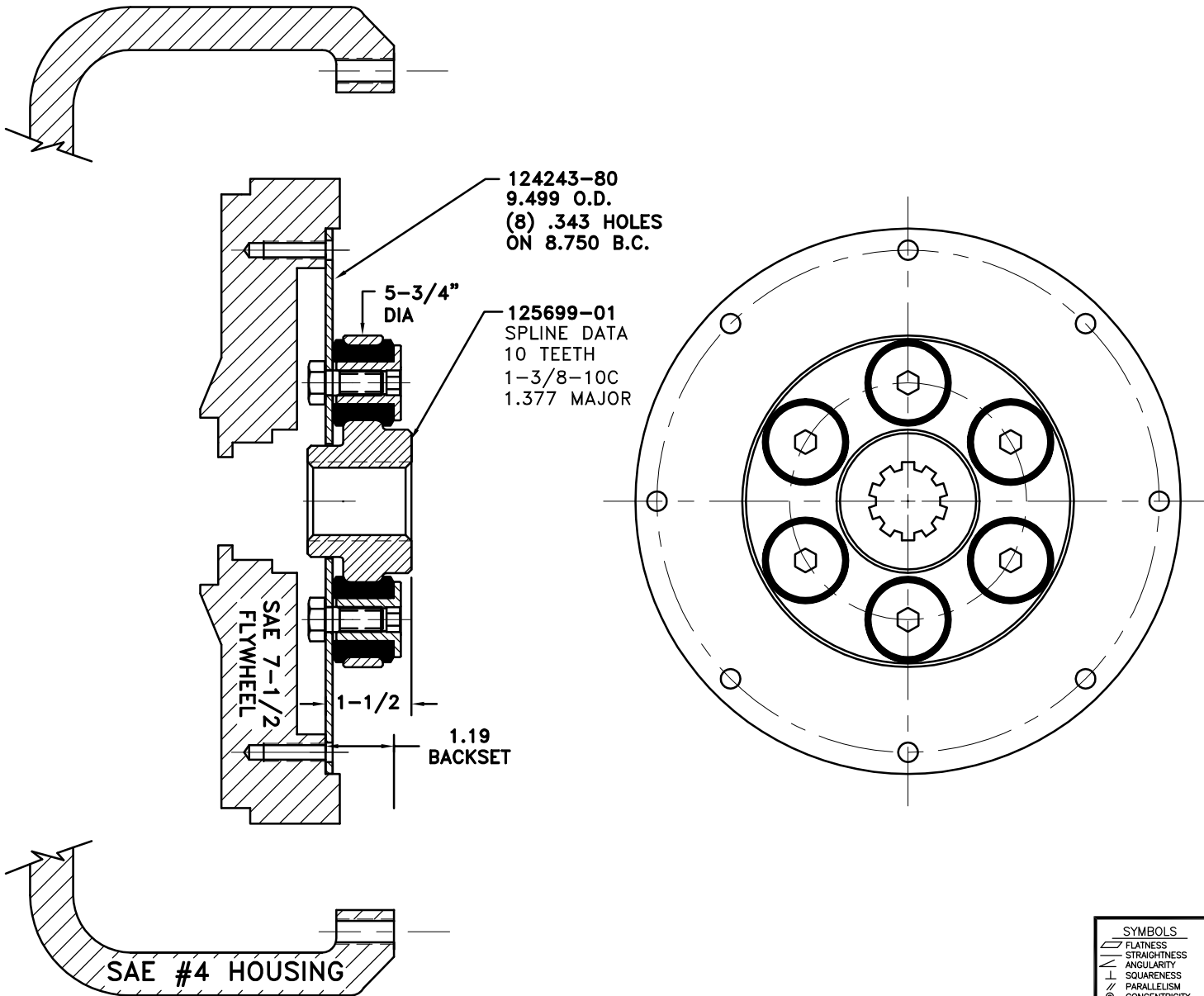

UP TO 110 HP

QTY.	PART NUMBER	DESCRIPTION
1	801912	GREASE
6	HX200	7/16-20x1 HHB
6	124412	THREADED BUSHING
6	H92500	NEOPRENE INSERT
1	125699-01	COUPLING HUB
1	124243-80	FLYWHEEL PLATE

SYMBOLS	DET.	PART NUMBER	DESCRIPTION	QTY.
<ul style="list-style-type: none"> — FLATNESS — STRAIGHTNESS — ANGULARITY — SQUARENESS — PARALLELISM — CONCENTRICITY — TRUE POSITION — ROUNDNESS — CIRCULAR RUN OUT — TOTAL RUN OUT — CYLINDRICITY — FINISH 	DO NOT SCALE DRAWING TOLERANCES UNLESS OTHERWISE SPECIFIED 125/ MAXIMUM ANGLE ±1/2° FRACTION ±1/32 DECIMAL .00 ±.01 .000 ±.005 .0000 ±.0005			
			TITLE FLYWHEEL COUPLING ASS'Y	
			MATERIAL	
			DRAWN BY HAYEMAN CHECKED BY RJH DATE 2-21-00 SCALE	DRAWING NO. 125776 SHEET OF REV.

THIS DRAWING IS THE PROPERTY OF HAYES MFG. INC. AND IS LOANED SUBJECT TO THE CONDITION THAT IT SHALL NOT BE REPRODUCED, COPIED, LOANED OR OTHERWISE DISPOSED OF, DIRECTLY OR INDIRECTLY. IT SHALL BE USED AS A MEANS OF REFERENCE TO WORK FURNISHED BY THIS COMPANY ONLY AND IS NOT TO BE SUBMITTED TO OUTSIDE PARTIES FOR EXAMINATION WITHOUT OUR CONSENT.