

SYM.	DATE	CHANGE DESCRIPTION	DWN.
A	03/01	CHANGED HUB WAS 125696	RH

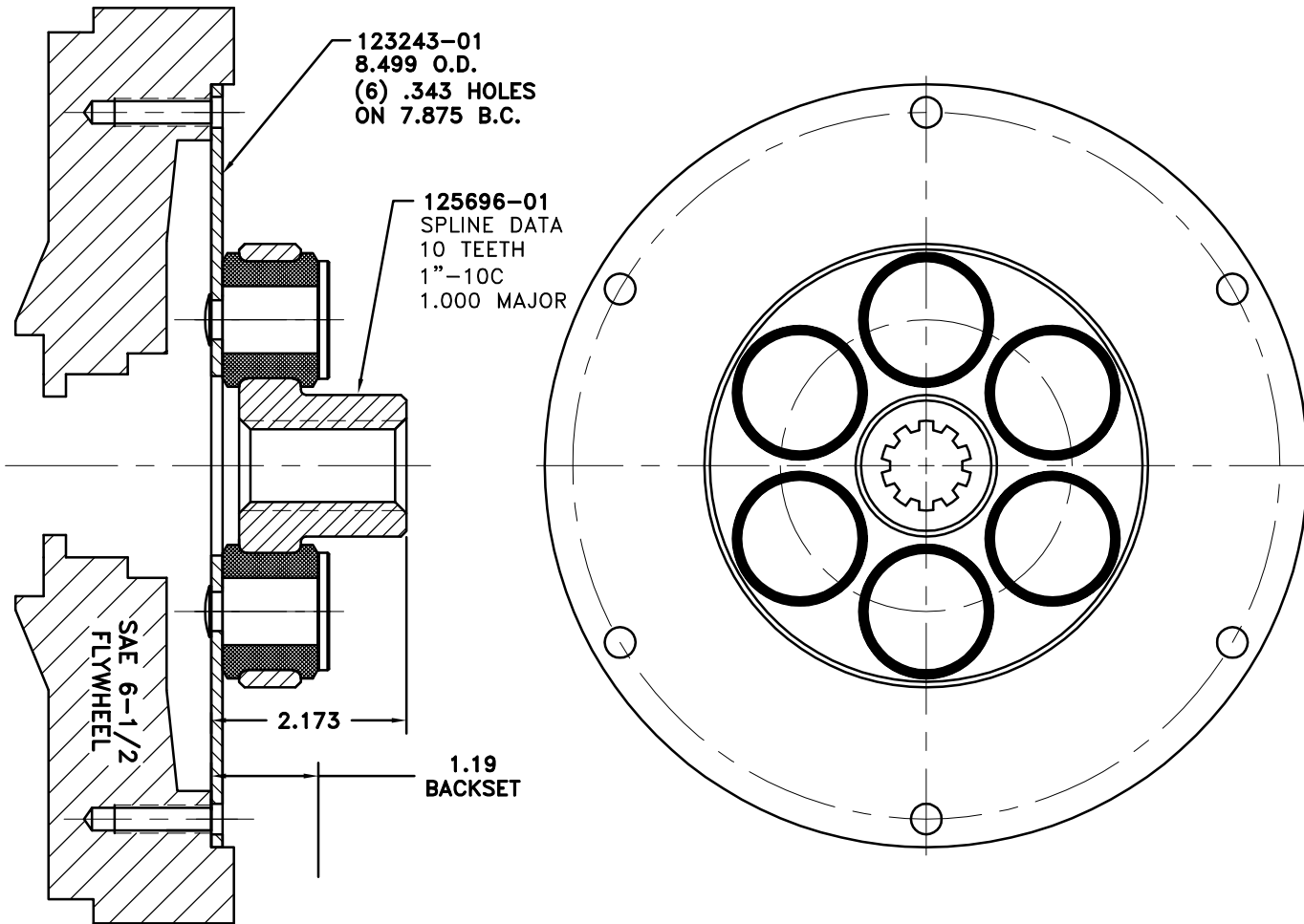

UP TO 65 HP

QTY.	DESCRIPTION	PART NUMBER
1	FLYWHEEL PLATE	123243-01
1	COUPLING HUB	125696-01
6	NEOPRENE INSERT	H92500
6	STEEL RIVET	125697
1	GREASE	801912

SYMBOLS	DET.	PART NUMBER	DESCRIPTION	QTY.
<ul style="list-style-type: none"> <li>▭ FLATNESS</li> <li>— STRAIGHTNESS</li> <li>∠ ANGULARITY</li> <li>⊥ SQUARENESS</li> <li>∥ PARALLELISM</li> <li>⊕ CONCENTRICITY</li> <li>⊙ TRUE POSITION</li> <li>⊘ ROUNDNESS</li> <li>⊙ CIRCULAR RUN OUT</li> <li>⊖ TOTAL RUN OUT</li> <li>⊘ CYLINDRICITY</li> <li>✓ FINISH</li> </ul>	DO NOT SCALE DRAWING TOLERANCES UNLESS OTHERWISE SPECIFIED 125/ MAXIMUM ANGLE ±1/2° FRACTION ±1/32 DECIMAL .00 ±.01 .000 ±.005 .0000 ±.0005			
TITLE <b>FLYWHEEL COUPLING ASS'Y</b>				
MATERIAL				
- UNLESS OTHERWISE SPECIFIED - REMOVE FIRST THREAD ON ALL TAPPED HOLES BREAK ALL SHARP CORNERS .010 TO .020 STAMP OR MARK DRAWING NO.		DRAWN BY <b>HAVEMAN</b>	DATE <b>2-21-00</b>	DRAWING NO. <b>125807</b>
		CHECKED BY SCALE		SHEET OF REV. 125807 OF

THIS DRAWING IS THE PROPERTY OF HAYES MFG. INC. AND IS LOANED SUBJECT TO THE CONDITION THAT IT SHALL NOT BE REPRODUCED, COPIED, LOANED OR OTHERWISE DISPOSED OF, DIRECTLY OR INDIRECTLY. IT SHALL BE USED AS A MEANS OF REFERENCE TO WORK FURNISHED BY THIS COMPANY ONLY AND IS NOT TO BE SUBMITTED TO OUTSIDE PARTIES FOR EXAMINATION WITHOUT OUR CONSENT.

REF: EPS