

REV	DATE	CHANGE DESCRIPTION	MOD. BY	CK1	CK2
A	05/09/2005	ADDED BACKING PLATE	ZS	RJH	HM

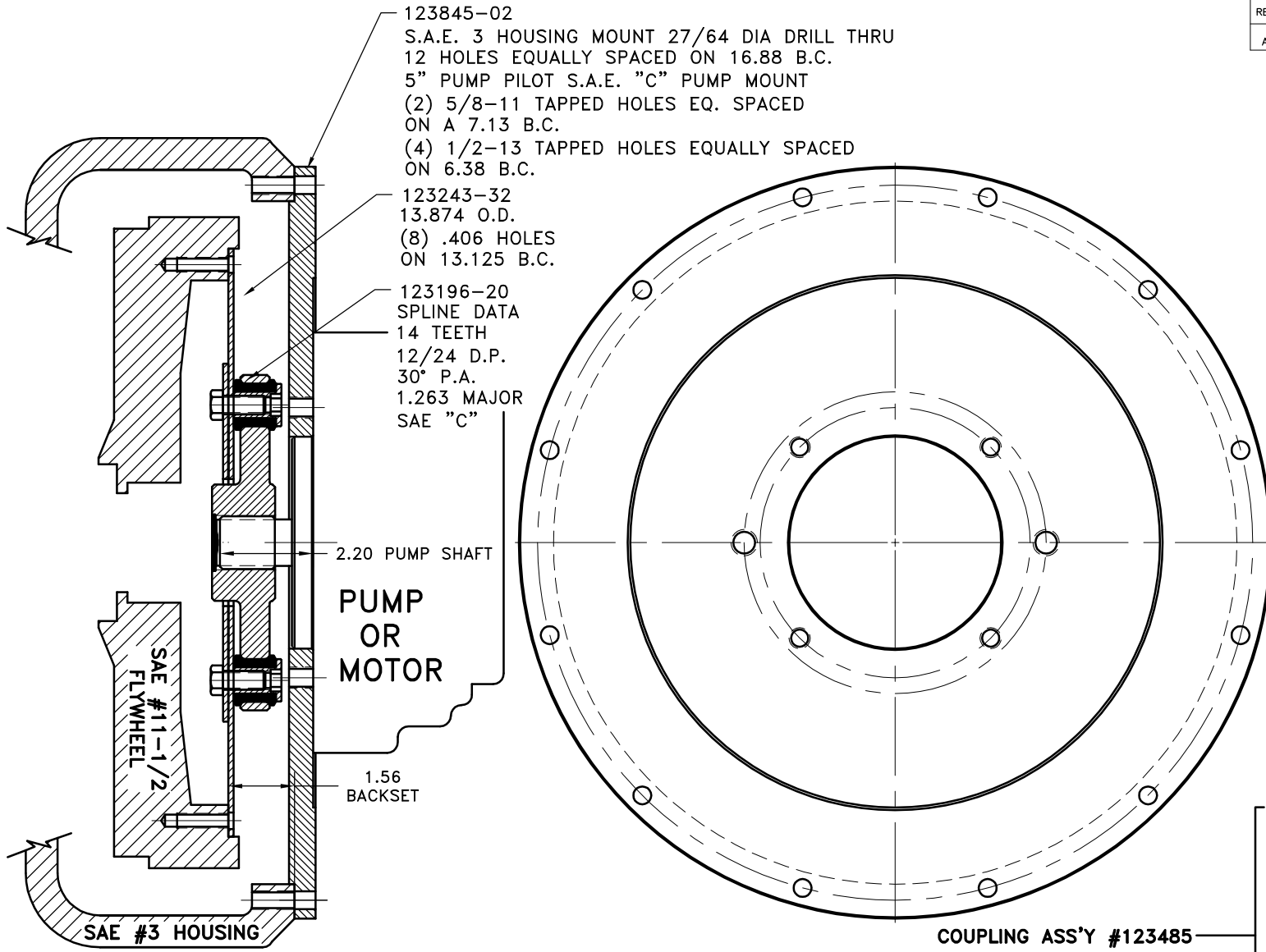

123845-02
 S.A.E. 3 HOUSING MOUNT 27/64 DIA DRILL THRU
 12 HOLES EQUALLY SPACED ON 16.88 B.C.
 5" PUMP PILOT S.A.E. "C" PUMP MOUNT
 (2) 5/8-11 TAPPED HOLES EQ. SPACED
 ON A 7.13 B.C.
 (4) 1/2-13 TAPPED HOLES EQUALLY SPACED
 ON 6.38 B.C.

123243-32
 13.874 O.D.
 (8) .406 HOLES
 ON 13.125 B.C.

123196-20
 SPLINE DATA
 14 TEETH
 12/24 D.P.
 30° P.A.
 1.263 MAJOR
 SAE "C"

2.20 PUMP SHAFT

PUMP
 OR
 MOTOR

1.56
 BACKSET

SAE #11-1/2
 FLYWHEEL

SAE #3 HOUSING

COUPLING ASS'Y #123485

UP TO 250 H.P.

REV	PART NUMBER	DESCRIPTION	QTY.
9	123845-02	PUMP MOUNT PLATE	1
8	801912	GREASE	1
7	HP-1312-S-62	HUBBARD PLUG	1
6	HX200	7/16-20 x 1" HHB	10
5	123727	THREADED BUSHING	10
4	H62500	NEOPRENE INSERT	10
3	123196-20	COUP HUB [14T 12/24\6.500]	1
2	124961-01	BACKING PLATE	1
1	123243-32	FLYWHEEL PLATE [11.5\6.500]	1

SYMBOLS	DET.	PART NUMBER	DESCRIPTION	QTY.
▭ FLATNESS — STRAIGHTNESS ∠ ANGULARITY ⊥ SQUARENESS ∥ PARALLELISM ⊕ CONCENTRICITY ⊙ TRUE POSITION ○ ROUNDNESS ⊖ CIRCULAR RUN OUT ⊖ TOTAL RUN OUT ⊖ CYLINDRICITY ✓ FINISH	DO NOT SCALE DRAWING TOLERANCES UNLESS OTHERWISE SPECIFIED 125 MAXIMUM ANGLE ±1/2° FRACTION ±1/32 DECIMAL .00 ±.01 .000 ±.005 .0000 ±.0005			
- UNLESS OTHERWISE SPECIFIED - REMOVE FIRST THREAD ON ALL TAPPED HOLES BREAK ALL SHARP CORNERS .010 TO .020 STAMP OR MARK DRAWING NO.			TITLE FLYWHEEL COUPLING ASSY WITH PUMP MOUNT PLATE MATERIAL	DRAWN BY SIETING CHECKED BY RJH
		DATE 04-27-00 SCALE	DRAWING NO. 125920 SHEET OF REV.	

THIS DRAWING IS THE PROPERTY OF HAYES MFG. INC. AND IS LOANED SUBJECT TO THE CONDITION THAT IT SHALL NOT BE REPRODUCED, COPIED, LOANED OR OTHERWISE DISPOSED OF, DIRECTLY OR INDIRECTLY. IT SHALL BE USED AS A MEANS OF REFERENCE TO WORK FURNISHED BY THIS COMPANY ONLY AND IS NOT TO BE SUBMITTED TO OUTSIDE PARTIES FOR EXAMINATION WITHOUT OUR CONSENT.